

# Hanwha Precision Machinery / Machine Tool Division

www.hanwhaprecisionmachinery.com

9 Sungsanpaechong-ro, Sungsan-gu, Changwon, Kyungnam, South Korea(59 Sungsan-dong)

Tel. +82-55-280-4678 / +82-55-210-6419 Fax. +82-55-280-8930

Hanwha Precision Machinery

Indian Dealer- Kiseki Machinery,

Plot No: 1992, J- Block, 3rd Street, Annanagar, Chennai- 600040, Tamilnadu, India.

Ph: +918807426744, +91 8248583211, Email: mgr@kisekimachinery.com, info@kisekimachinery.com

Web: www.kisekimachinery.com



## Hanwha Europe GmbH

Kölner Straße 10, 65760 Eschborn Germany

## Hanwha Europe GmbH Technical Center

Hessenring 15B, 64546 Mörfelden-Walldorf, Germany

· Tel. +49-(0)-6105-7035-911

· Email. wsjung@hanwha.de

## EUROPE

Germany · Italy · Russia · Switzerland · Spain  
Belgium · Netherland · Latvia · Ukraine  
France · Portugal · Czech Republic · Poland  
Hungary · Romania · Belarus · Bulgaria  
Finland · Sweden · Turkey

## ASIA

China · Hong Kong · India · Philippines  
Israel · Thailand · Indonesia · Malaysia  
Vietnam

## AMERICA

U.S.A · Canada · Brazil · Argentina · Mexico  
Venezuela · Costa Rica · Colombia

## Hanwha Machinery America Inc.

9750 South Oakwood Park Drive, Franklin, WI 53132, USA

www.hanwhamachinery.com

· Tel. +1-414-421-2300

· E mail. brian@hanwhamachinery.com

Experience Your **SMART FACTORY**

# Hanwha Machine Tool

CNC Swiss Turning Lathe

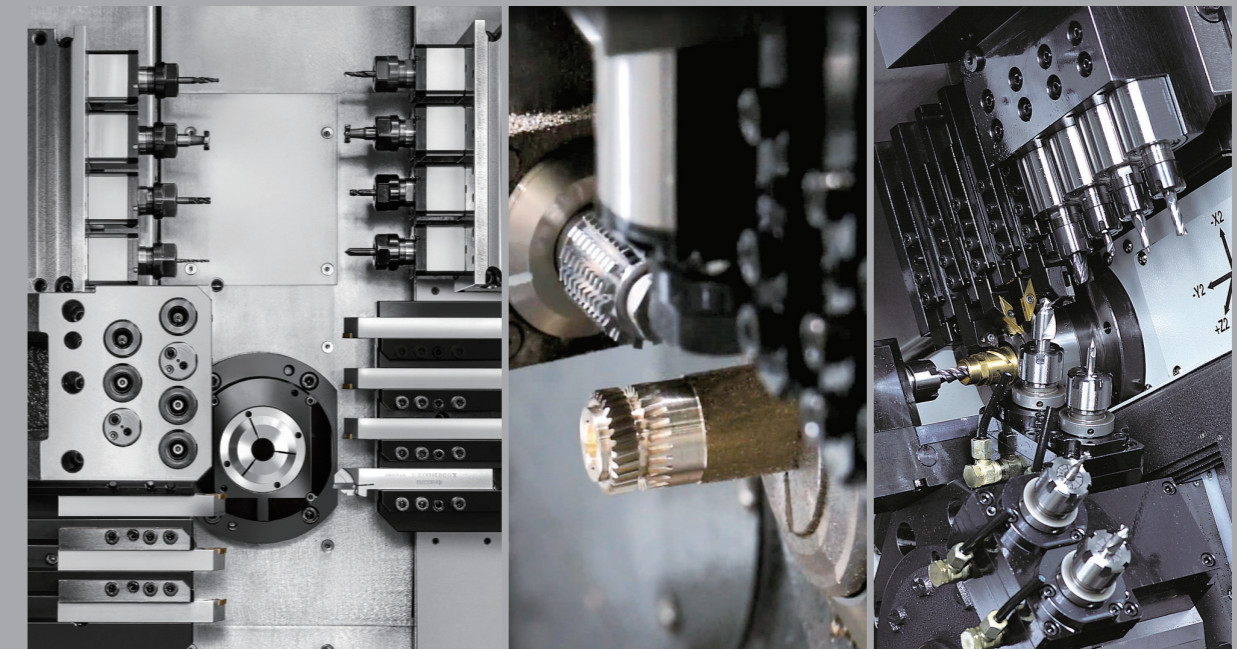

2021. Apr © 2021 Hanwha Precision Machinery Co., Ltd. All rights reserved.



# Enjoy Total Engineering Solution

After starting the machine tool business in 1977, Hanwha Precision Machinery has become a leading worldwide Smart Factory solutions provider, offering Surface Mount Technology (SMT) mounters, Machine Tool, industrial automation equipment, and integrated software solutions. We do this to develop customer-oriented solutions that deliver greater efficiency, versatility and value.

## Machine Tool Division

### CNC Swiss turning Lathe

Offers customized solutions with a wide range of line-up for automatic lathes in gang & turret type.



## Surface Mounter Technology Division

### Chip Mounter • Screen Printer • Semiconductor Equipment

After developing its first chip mounter, offers SMT mounters, semiconductor equipment, industrial automation equipment and software solutions.

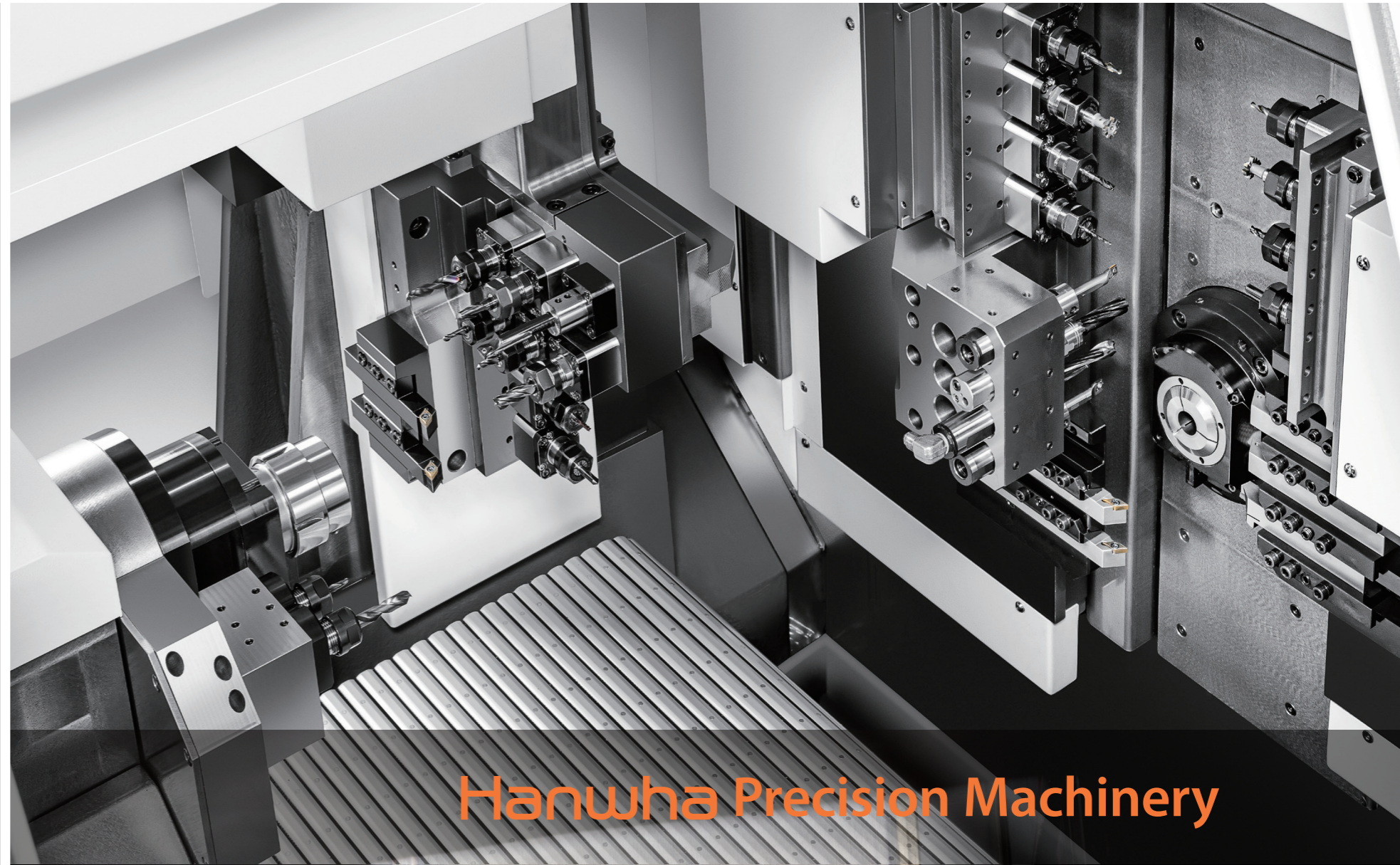

Hanwha Precision Machinery

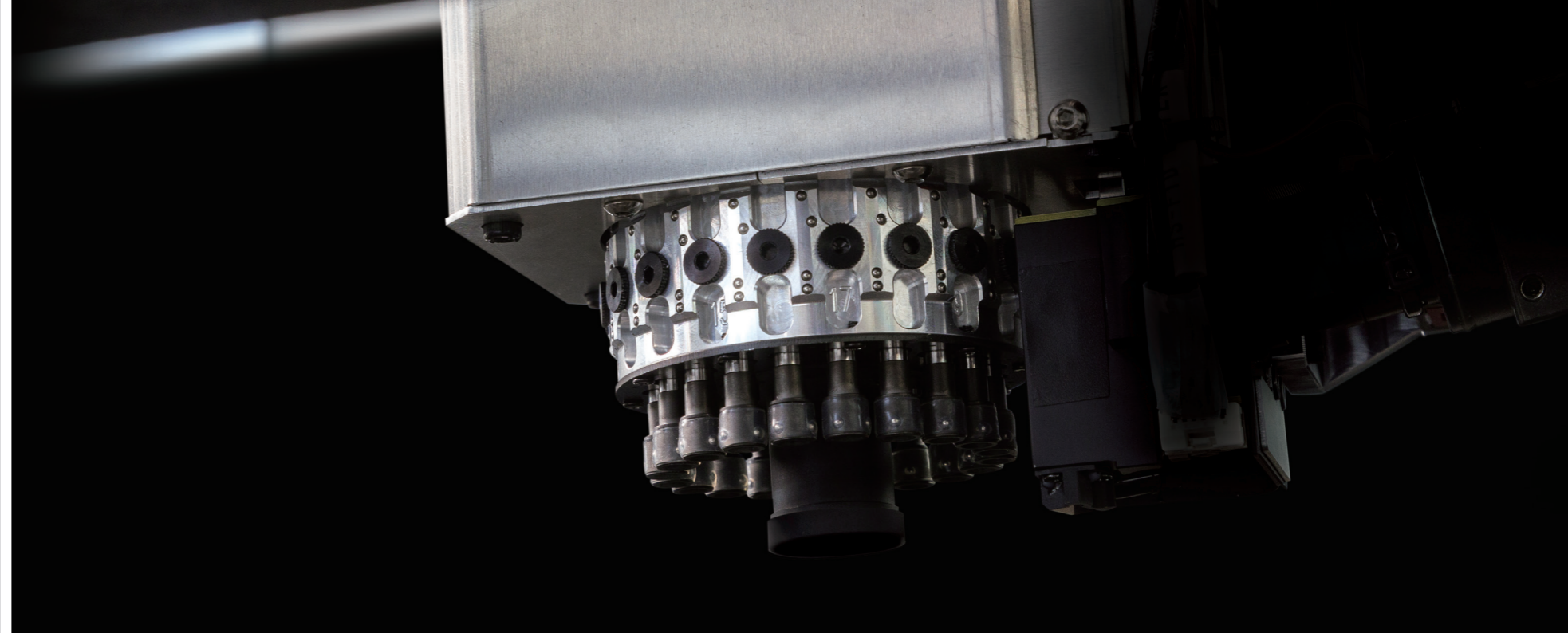

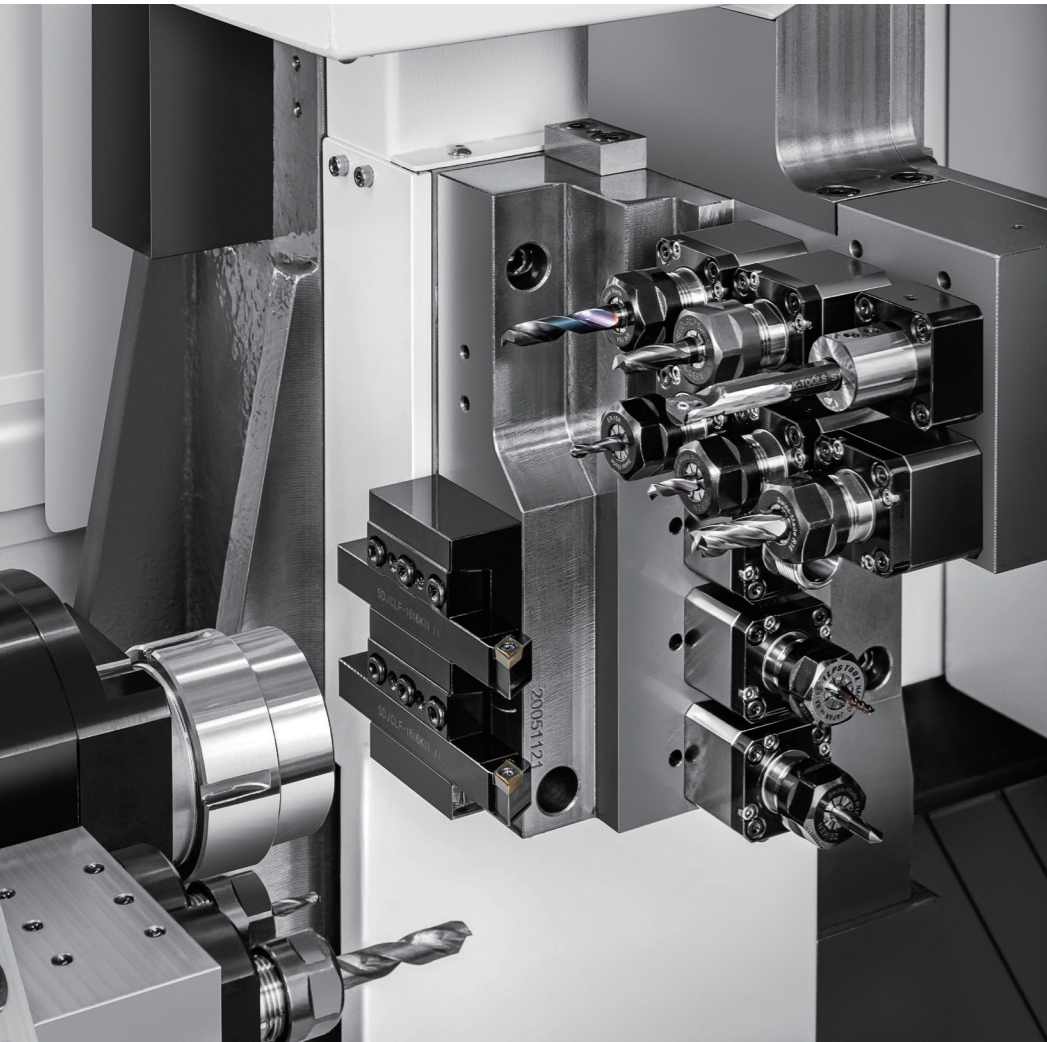

## CNC Swiss Turning Lathe

Provides the best customized machining solution with a wide range of line-up from Ø10mm to Ø42mm and various options

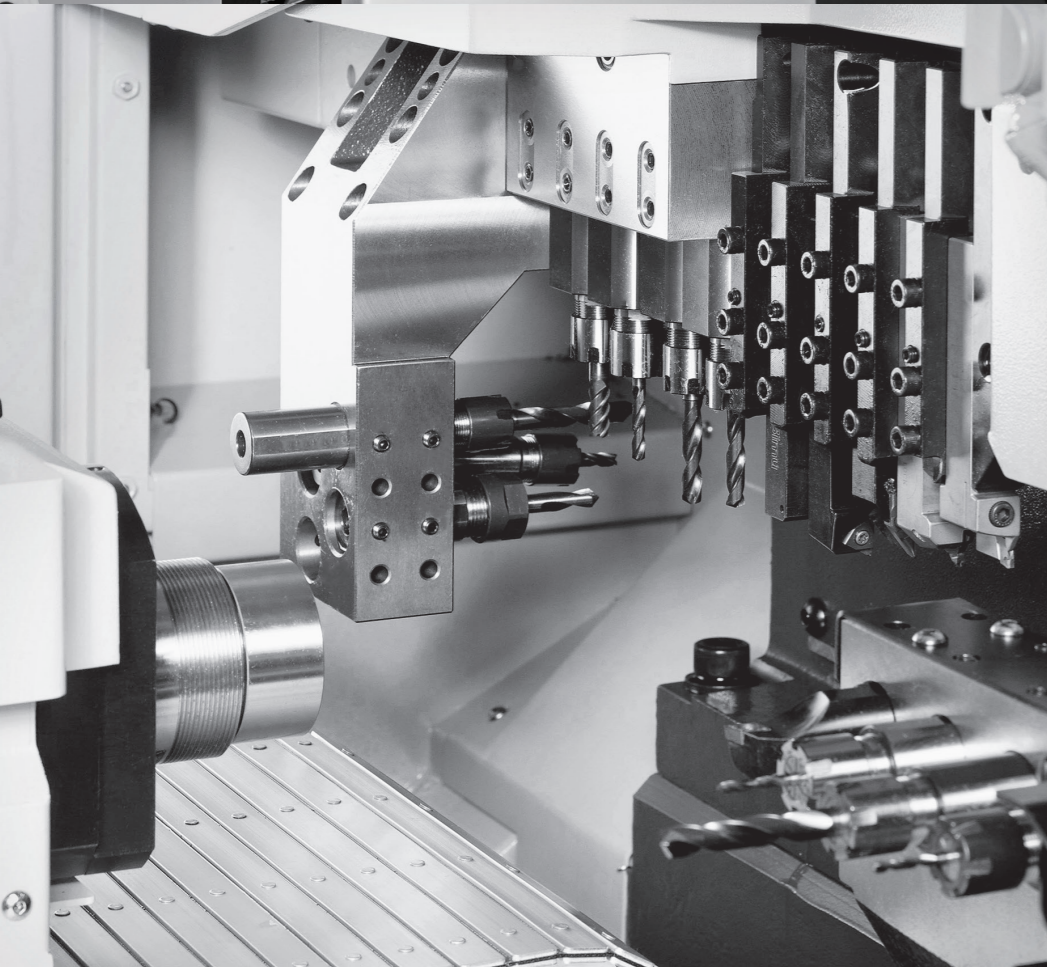

# Machine Tool Division

## Turning forward to the Future

Starting the machine tool business 1977 and developing its first CNC Swiss turning machine in 1998, Hanwha machine tool division has been focusing on product development to best fit customer's various needs and resulted in a wide range of line-up of excellent gang & turret type series. We, as a leading Swiss turning solution provider, will continue to strive to reach the top position in the machine tool business, accelerating our innovation and growth based on our +50 years of business experience and ever-expanding Hanwha global network.

To be the Global  
**No.**

Exports to more than  
**30 countries** in the world



- **2021**  
3-path 9 axis swiss turn, XDI 26/32
- **2020**  
High-complex turret type, STL42  
High-productive model, XD10
- **2010**
  - 2019 XD38II-R, heavy duty cutting model
  - Established Europe technical center in Germany
  - 2018 Hi-CPS, Smart Factory MES system
  - XD20/26II-V, high complex model
  - 2016 Upgraded line-up; XD-II, XE series
  - XD12/16III, XD42
  - 2014 Established Hanwha machinery Suzhou in China
  - Opened Stuttgart office in Germany
  - 2010 XD07, compact and precise machine
- **2000**
  - 2008 Opened Milwaukee office in U.S.A
  - 2006 XD20N, the first non-guide bush type  
CNC automatic lathe in Korea
  - XD32/35 series
  - 2005 XP series, 4-axis CNC automatic lathe
  - 2004 Opened Suzhou office in China
  - XD20H, CNC automatic lathe
- **1990**
  - 1998 ML series, the first CNC automatic lathe in Korea
  - 1994 Centerless grinding machine KCG-200J
  - 1992 The first internal grinding machine
- **1983**  
SAL-10, the first cam type lathe in Korea
- **1977**  
Started machine tool business



# STL42

Specialized 9-axis turret type sliding head machine with powerful Siemens 840D controller (42mm)



**OPTION**  
• Back tool cross 9 (Cross 3, Driven 3 + Fixed 3)

Model	STL42	
	H	NH
NC	Siemens 840D	
Max. machining diameter (mm)	Ø42	
Z1 Stroke (mm)	420	282 (H), 125 (N)
Main spindle	Speed (rpm)	6,000
	Motor (kW)	22
OD tool	No. of tools	5 (□20mm)
	No. of tools	5 (ER20)
Cross drill	Speed (rpm)	6,000
	Motor (kW)	2.59
Turret unit	No. of unit	1 Unit (10 Station)
	No. of tools	max. 30EA (□20mm, ER20)
	Tool type	VDI 30 (Option : BMT 45)
Sub spindle	Speed (rpm)	6,000
	Motor (kW)	22
Back tool	No. of tools	9 (ER20) (3 Fixed + 6 Driven)
	Speed (rpm)	6,000
	Motor (kW)	2.13
Machine size(L x W x H) (mm)	3,580 x 2,060 x 1,980	
Weight (kg)	7,330	
Power consumption (Cable size)	40kVA, 26.7kW (VCTF 16SQ x 4C)	
Air flow rate (Liter/Min)	20 ~ 30 (Hydraulic device capacity : 30L)	

### OPTIMIZATION OF STRUCTURE & SPEC

Adopted built-in motor with hydraulic chucking cylinder for strong chucking power

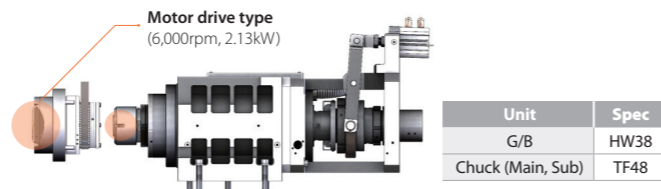

### UPGRADED SOFTWARE PLATFORM

Provides the new HMI screen and improved software functions for machining & operating convenience

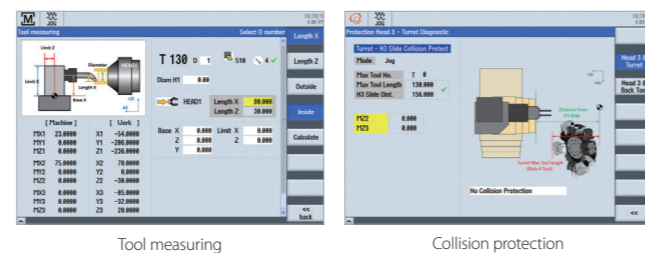

### Dimension

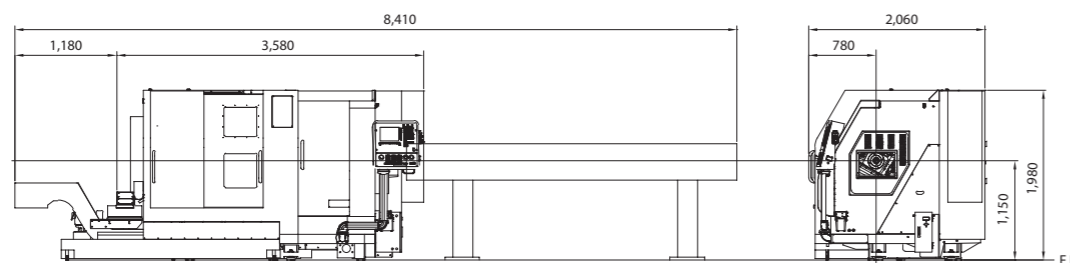

## Option Tooling

Max. 49 tools with gang & turret tool post are available, and structure, spec & tooling are optimized for material 42mm

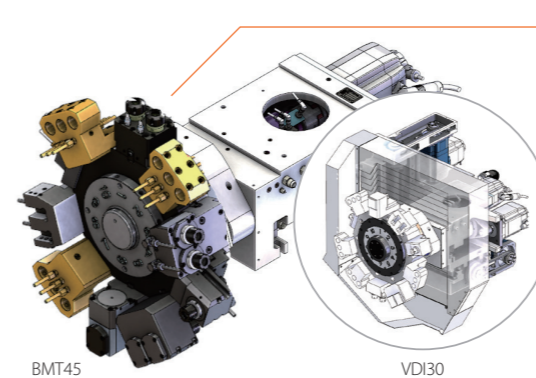

### Turret Unit

- Type of turret unit is selectable; VDI (standard) or BMT (option)
- Adopted SRG(Roller retainer) LM guide for feed of turret unit

#### Specification

- Driven : 6,000rpm, 2.59kW
- Tool size : □20, ER20
- 10 station
- Max. number of tools : 30
- Tool holder type : VDI30(standard), BMT45(option)

### Cross Drilling / Milling Unit

- Optimized structure for machining large bore material
- Extended distance between tools & increased no. of tools

#### Specification (STL38 → STL42)

- Tool distance : 35mm → **60mm**
- Tool spec : 4(ER20M) → **5(ER20)**
- Motor spec : 6,000rpm, 1.07kW → **2.13kW**

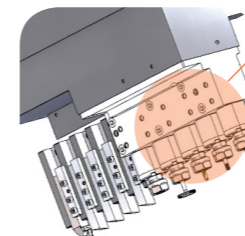

### Back Tool Unit

- Enhanced machining capability with Y3-axis feed & increased no. of tools for back
- Simultaneous processing & high complex machining with back tool cross unit (option)

#### Specification (STL38 → STL42)

- Tool distance : 40mm → **60mm**
- Tool spec : 8(ER20M) → **9(ER20)**
- Motor spec : 6,000rpm, 1.07kW → **2.13kW**

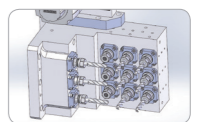

※ Back tool Cross unit (Option)  
→ No. of tools : Back tool 6, Cross 3

### COMPLEX MACHINING

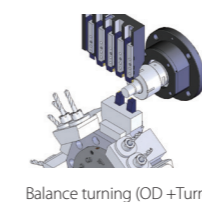

Balance turning (OD+Turret)

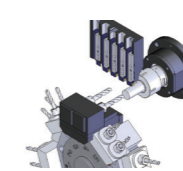

Turning/drilling (OD+Turret)

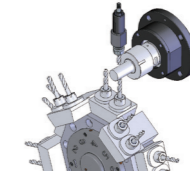

Endmill (Cross+Turret)

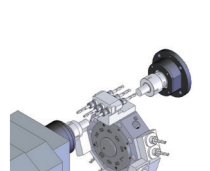

Drilling (Front+Back)

### Standard

- Main-Sub Cs control (0.001°)
- Rotary Guide bush holder
- MPG
- Chip conveyor
- Door interlock
- Work light
- Signal lamp (3color)
- Tool monitoring function
- Cut off tool breakage detector (S/W)
- Auto power off
- Bar feeder interface
- Middle pressure pump

### Option

- Bar feeder
- Transformer
- Tap breakage detector
- High pressure pump
- Oil mist collector
- Oil chiller
- Memory card
- Tooling & Programming
- Internal coolant driven tool (cross, back, off-center)
- NC warranty for 2 years
- Turret unit (BMT45)
- Turret Tool Holder

# STL38

Turret type, sliding head machine (9-axis) with powerful Siemens 840D controller

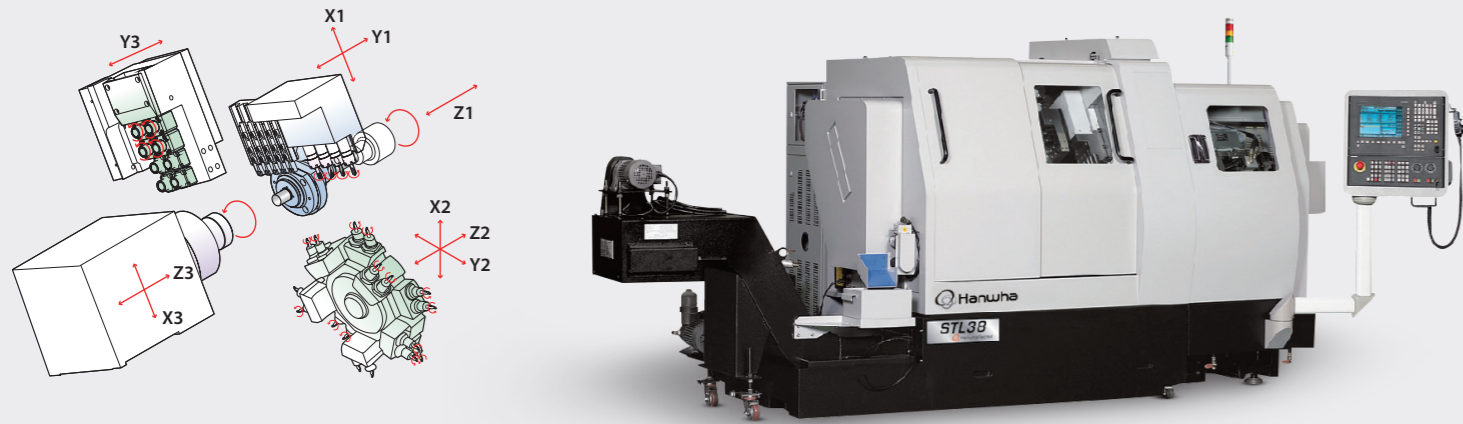

**OPTION**  
• Y3 back tool 8 (Driven 4 + Fixed 4)

Model	STL32/38		
		Y3	
NC	Siemens 840D		
Max. machining diameter (mm)	Ø32/38		
Z1 Stroke (mm)	320		
Main spindle	Speed (rpm)	6,500	
	Motor (kW)	23	
OD tool	No. of tools	5 (□16mm)	
	No. of tools	4 (ER20M)	
Cross drill	Speed (rpm)	6,000	
	Motor (kW)	1.07	
Turret unit	No. of unit	1 Unit (10 Station)	
	No. of tools	max. 30 (□20mm, ER20)	
	Tool type	VDI 30 (Option : BMT 45)	
Sub spindle	Speed (rpm)	6,500	
	Motor (kW)	23	
Back tool	No. of tools	3 (ER20M) (3 Fixed)	8 (ER20M) (4 Fixed + 4 Driven)
	Speed (rpm)	-	
	Motor (kW)	-	
Machine size (L x W x H) (mm)	3,130 x 1,860 x 1,780		
Weight (kg)	4,400	4,500	
Power consumption (Cable size)	40kVA, 26.7kW (VCTF 16SQ x 4C)		
Air flow rate (Liter/Min)	20 ~ 30 (Hydraulic device capacity : 30L)		

## COMPLEX MACHINING

Combination of gang & turret unit and 3 path control system enables complex machining in various shapes

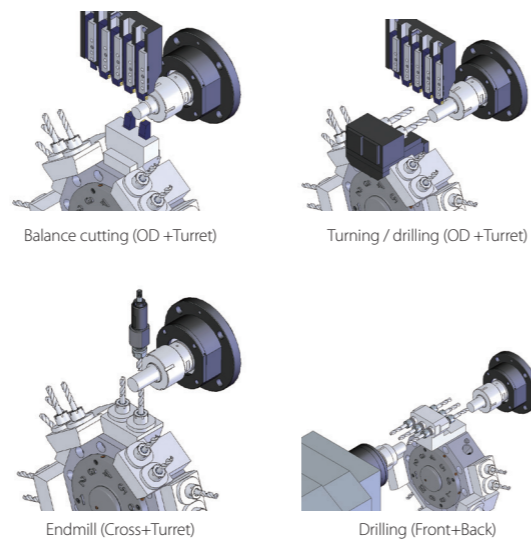

## Option Tooling

Max. 47 tools with gang & turret tool post are available, and customized high-complex tooling service is offered

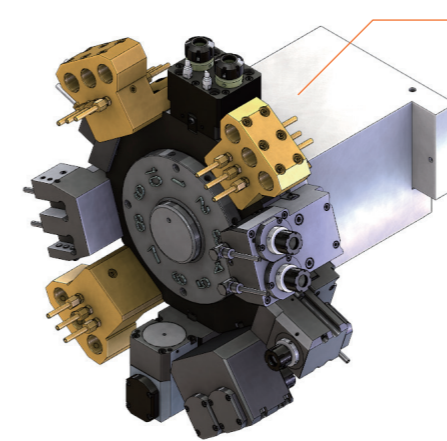

### Turret Unit

- Type of turret unit is selectable; VDI (standard) or BMT (Option)
- 1 set turret (10 station)
- Tool holder type : VDI30, BMT45
- Tool size : □20, ER20
- Max. number of tools : 30

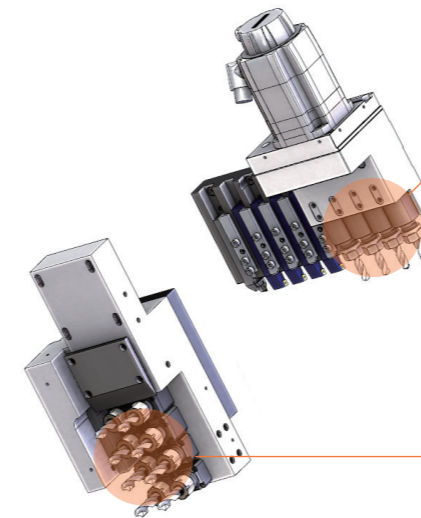
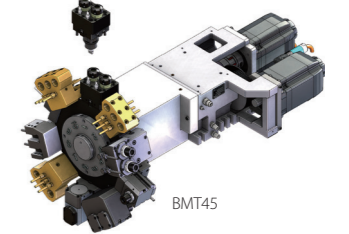
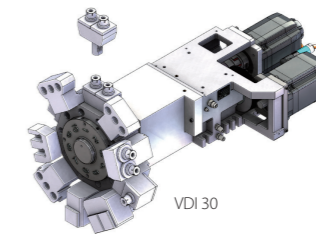

### Cross Drilling / Milling Unit

- Easy tool change for maintenance & installation

#### Option tool



### Back Tool Unit

- Fixed 3 tools as standard and 8 tools of Y3 (4 driven, 4 fixed, ER20M) are available in modular type

#### Option tool & unit

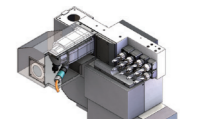
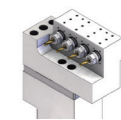

#### Specification of G/B & Chuck

No. of Back tool	3 Fixed	4 Fixed	8 (4 Driven + 4 Fixed, Y3)
G/B	HW38	HW38	HW38
Main Chuck	TF48	TF48	TF48
Sub Chuck	TF48	TF44	TF44

## Dimension

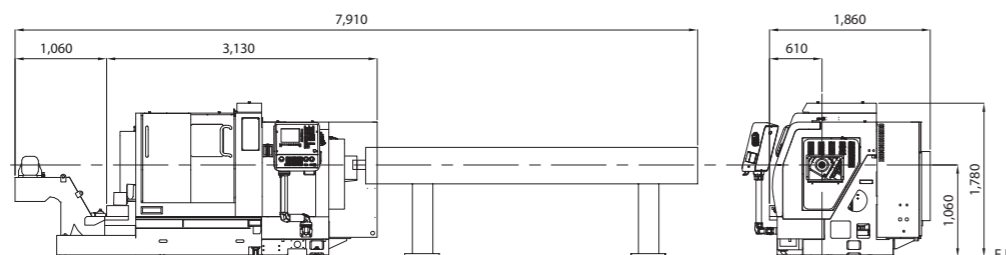

## Standard

- Main-Sub Cs control (0.001°)
- Rotary Guide bush holder
- MPG
- Chip conveyor
- Part conveyor
- Door interlock
- Work light
- Signal lamp (3color)
- Tool monitoring function
- Cut off tool breakage detector (S/W)
- Auto power off
- Bar feeder interface
- Middle pressure pump

## Option

- Bar feeder
- Transformer
- Tap breakage detector
- High pressure pump
- Oil mist collector
- Oil chiller
- Memory card
- Tooling & Programming
- Internal coolant driven tool (cross, back, off-center)
- NC warranty for 2 years
- Turret unit (BMT45)
- Turret Tool Holder

# Options

Customized special option units are available for qualified performance, enhanced productivity and convenience

Standard & Option Accessory		STL series		XDI series	XD series				XD series		XE series		XP series			
		STL42	STL38	XDI 26/32	XD42	XD38II-R	XD38II	XD20/26II-V	XD20/26II	XD16III	XD10	XE35	XE20/26	XP20/26/32S	XP12/16S	
Off-cent unit	Driven(2)	-	-	★	★(1)	★	★	★	★	-	-	★(1)	★	-	-	
	Fixed (long drill, 2)	-	-	★	-	★(1)	★(1)	★	★	★(1)	-	-	★	-	-	
	Off-center Tailstock	-	-	▲	★	★	★	★	★	-	-	★	★	-	-	
Intenal coolant driven unit	Cross	★	★	★	★	★	★	★	★	★(Modular)	▲	★	★	-	-	
	Back	★	★	★	★	★	★	★	★	-	▲	★	★	-	-	
	Off-center	-	-	▲	★	★	★	★	★	-	-	★	★	-	-	
Fixed angle drilling unit	Cross, 1	★	★	★	★	★	★	▲	▲	-	-	▲	▲	-	-	
	Back, 1	★	★	★	★	★	★	▲	▲	-	▲	▲	▲	-	-	
Option tool unit	Triple speed cross drill	★	★	▲	★	★	★	★	★	★(Modular)	▲	★	★	-	-	
	Triple speed reduction cross drill	★	★	▲	★	★	★	★	★	★(Modular)	▲	★	★	-	-	
	3 Face/counterface driven tool	-	-	▲	★	★	★	★	★	-	-	★	★	-	-	
	3 Face/counterface angle driven tool	-	-	▲	★	★	★	★	★	-	-	★	★	-	-	
	Gear hobbing	★(Turret)	★(Turret)	▲	★	★	★	★	★	▲	▲	★	★	-	★	
	Whirling	★	★	▲	★	★	★	★	★	★	-	★	★	-	-	
	Side cutter	★(Turret)	★(Turret)	▲	★	★	★	★	★	★	★	★	★	-	-	
	Back tool cross	Modular(Y2)	-	-	★	★	★	★	★	-	★	-	-	-	-	-
		Single body(Y2)	★(Y3)	-	-	-	★	★	★	★	-	▲	-	-	-	-
		Horizontal	-	-	★	★	★	★	★	★	-	▲	★	★	-	-
Coolant unit	Chiller integrated High pressure coolant pump	★	★	★	★	★	★	★	★	★	★	★	★	★	▲	
	Extended coolant tank	-	-	★	★	★	★	★	★	★	★	★	★	★	★	
Chip conveyor	Standard chip conveyor	-	-	★	★	★	★	★	★	★	★	★	★	★	★	
	Smart chip conveyor	-	-	▲	★	★	★	★	★	-	-	★	-	-	-	
	Lower type chip conveyor	★	★	▲	★	★	★	★	★	★	-	★	★	★	★	

★ : Option ▲ : Discussable - : N/A

# Special Accessories

## Swing Gripper

Gripper fingers to grip and release finished parts on to conveyor belt for ejection

- Applied example : vulnerable material, long parts

• XD20/26II, XD38II, XD42, XE20/26

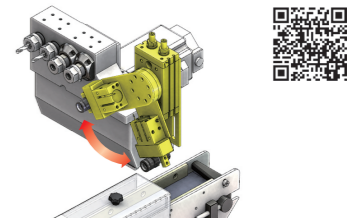

## Parts Auto Loading unit

Auto loader for forged or diecasted parts to supply through main spindle door

• XD20/26II, XD38II, XD42, XE20/26

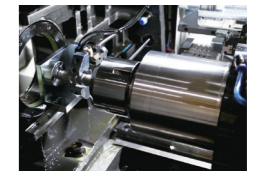

## Auto stacking unit for machined parts

Auto loader for ejected parts onto a stacking pallet

• XD38II



# Tooling Variation

## XD20/26II

- Front/Back Tool
- Cross Drill
- Special Option Tool
- OD Tool

Cross 4

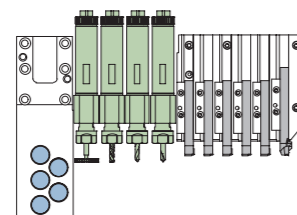

Cross 5

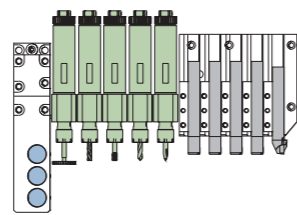

Cross 6

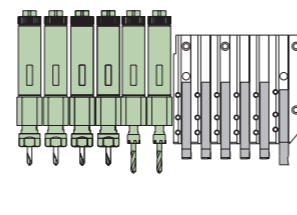

3 Face/counterface angle driven tool

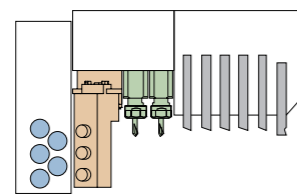

Angle: -20° ~ 0°

3 Face/counterface driven tool

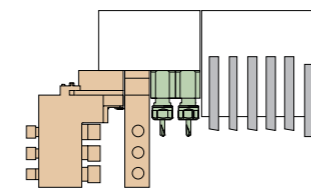

Angle: -90° ~ 0°

3 Face/counterface driven tool

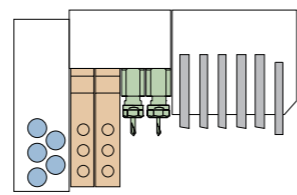

• Back tool : Max. 5 (1 unit applied)  
Max. 4 (2 unit applied)

Whirling

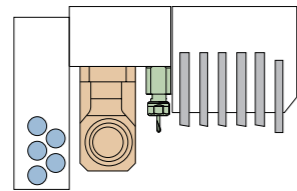

Gear Hobbing

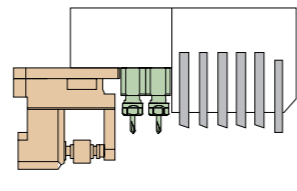

Polygon

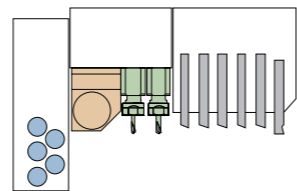

※ When special tool is installed, back tool unit should have max. 4 tools

## XD38II

- Front/Back Tool
- Cross Drill
- Special Option Tool
- OD Tool

Cross 5

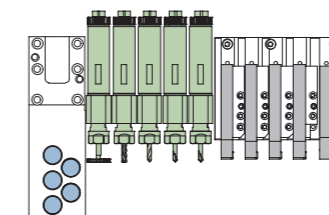

Cross 6

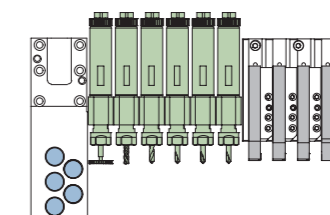

B-axis unit

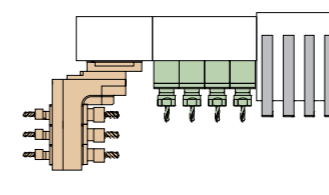

• 3 Face driven tool can be limited the number of back tool

Fixed Angle Drilling

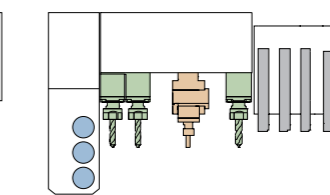

• Angle will be set as per requested

## Back Tool Option Unit (Y2)

### Fixed Angle Drilling

• Angle will be set as per requested

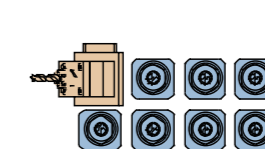

### Back tool cross (Modular, Single body)

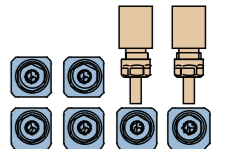

※ When special tool is installed, back tool unit should have max. 4 tools  
※ Back tool option is available for both 6(Y2) and 8(Y2)

# Hi-CPS

## Hanwha Intelligence CNC Prognostic System



Hi-CPS is a kind of smart factory solution to enable customers to manage factory in a smart & convenient way by providing real time onitoring on running status of machines at the facility. It is a cloud-based system so that one can access with ease from anywhere through internet.

### Function

- 1 Monitoring**
  - Monitors machine operation status from PC & Mobile
  - Check machining, repair, alarm, cycle time, etc.
- 2 Diagnosis**
  - Remotely examines alarmed machines at user's online request
  - ※ Only at customer's request, relevant machine data will be auto-transferred to Hanwha for analysis
- 3 Prognosis**
  - Analyzes cutting load, tool change and offset

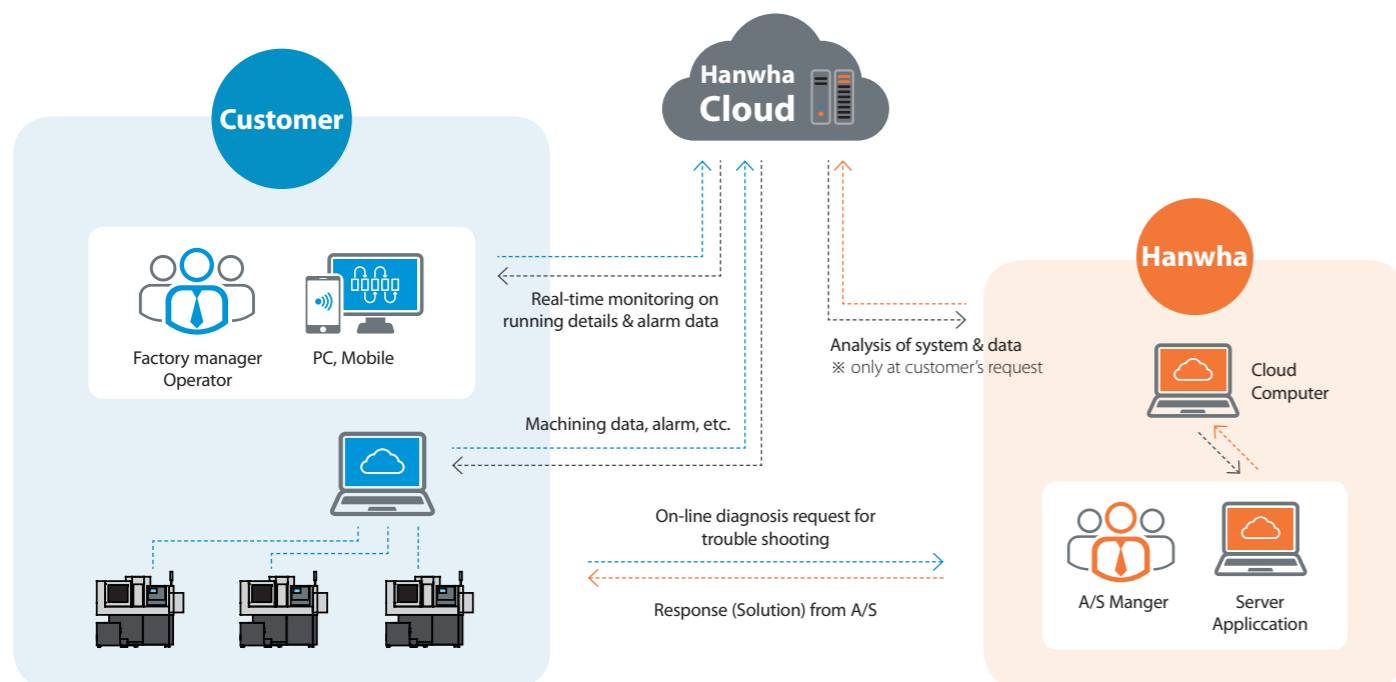

# PCR / PCRS & Oscillation

## Chip breaking solution



Hanwha provides chip cutting solution to break long and curled chips into small pieces through macro program.

### Advantage

- Better tool life
- Build-up edge free
- Chip trouble free
- Coolant usage saved



Model	PCR	PCRS	Oscillation
NC	FANUC 32i-B	SIEMENS 828D/840D	Fanuc 0i-TD / 0i-TF / 32i-B
Front turning	•	•	•
Back turning	•	•	•
Back drilling	Fixed drills	•	Fixed drills
Taper	•	•	45° angle
Circular interpolation	•	•	•
Synchronous control	•	•	x
Threading	•	•	x
Nose R compensation	x	•	x

# Customer & Performance Supporting Function

Hanwha offers various software for enhancing machining performance & supporting customer's convenience.

- Quick Measuring**  
**Setting time reduce system**  
 Supports tools setting with minimal control and none of screen change
- Collision Protection**  
 Easy setting of value to protect collision before occurring
- Tool Load Monitoring**  
 Alarms when abnormal load on tools are detected
- M7**  
 Single code to command cut-off of material
- 3D Chamfer Solution**  
 Uniform chamfer machining on cross hole with input of single code
- G301**  
 Single code to set the position of Z2-axis for cut-off of material
- Motion Optimization**  
**C/T reduce system**  
 Reduces cycle time by minimizing unnecessary motion (non processing time)
- Help function**  
 Provides description & graphic information about codes & alarms with



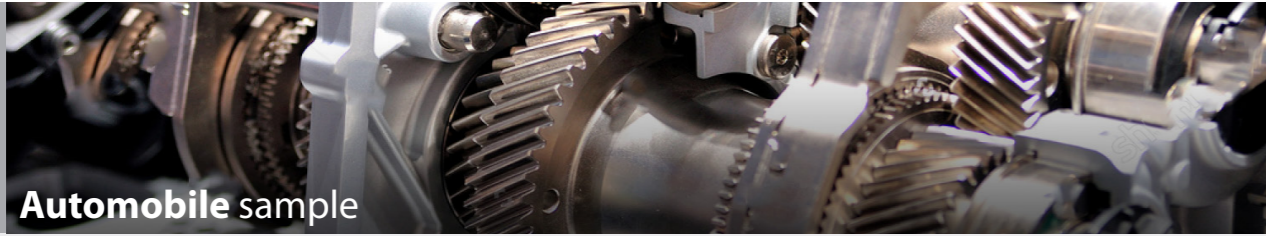

Automobile sample



Electronic sample



Industrial sample



Medical sample

NO. Material	 <b>A001</b> SUM22	 <b>A002</b> SUS304	 <b>A003</b> SCM440H
NO. Material	 <b>A004</b> SUS304	 <b>A005</b> SUS304	 <b>A006</b> SUS304
NO. Material	 <b>A007</b> SUM22	 <b>A008</b> SUS630	 <b>A009</b> SUM24
NO. Material	 <b>A010</b> AL6062-T8	 <b>A011</b> AL6062-T8	 <b>A012</b> AL6062-T9
NO. Material	 <b>A013</b> Brass	 <b>A014</b> AL-Die Casting	 <b>A015</b> SUM22
NO. Material	 <b>A016</b> SUS316	 <b>A017</b> SUS304	 <b>A018</b> SUS303
NO. Material	 <b>A019</b> SCM315	 <b>A020</b> AL6062	 <b>A021</b> Brass
NO. Material	 <b>A022</b> AL6061	 <b>A023</b> SUS304	 <b>A024</b> SUM202

NO. Material	 <b>E001</b> SUS316	 <b>I001</b> AL6062	 <b>M001</b> Titanium
NO. Material	 <b>E002</b> AL6061	 <b>I002</b> SUS316	 <b>M002</b> SUS316L
NO. Material	 <b>E003</b> AL6062	 <b>I003</b> AL2024	 <b>M003</b> Titanium
NO. Material	 <b>E004</b> AL6061	 <b>I004</b> AL2024	 <b>M004</b> Titanium
NO. Material	 <b>E005</b> Brass	 <b>I005</b> AL6062	 <b>M005</b> Titanium, Brass
NO. Material	 <b>E006</b> AL6061	 <b>I006</b> AL6062	 <b>M006</b> Titanium, Brass
NO. Material	 <b>E007</b> Brass	 <b>I007</b> SUS316	 <b>M007</b> SUS316
NO. Material	 <b>E008</b> AL6062	 <b>I008</b> Brass	 <b>M008</b> Titanium