

# Hanwha Precision Machinery / Machine Tool Division

www.hanwhaprecisionmachinery.com

9 Sungsanpaechong-ro, Sungsan-gu, Changwon, Kyungnam, South Korea(59 Sungsan-dong)

Tel. +82-55-280-4678 / +82-55-210-6419 Fax. +82-55-280-8930

**Hanwha Precision Machinery**

Authorized Indian Dealer

Kiseki Machinery

Plot No: 1992, J- Block, 3rd Street, Annanagar, Chennai- Tamilnadu- 600040, India

Emai: mgr@kisekimachinery.com, Ph: +91 8807426744, 8248583211,web: kisekimachinery.com



## Hanwha Europe GmbH

Kölner Straße 10, 65760 Eschborn Germany

## Hanwha Europe GmbH Technical Center

Hessenring 15B, 64546 Mörfelden-Walldorf, Germany

· Tel. +49-(0)-6105-7035-911

· Email. wsjung@hanwha.de

## Hanwha Machinery America Inc.

9750 South Oakwood Park Drive, Franklin, WI 53132, USA

www.hanwhamachinery.com

· Tel. +1-414-421-2300

· E mail. brian@hanwhamachinery.com

## EUROPE

Germany · Italy · Russia · Switzerland · Spain  
Belgium · Netherland · Latvia · Ukraine  
France · Portugal · Czech Republic · Poland  
Hungary · Romania · Belarus · Bulgaria  
Finland · Sweden · Turkey

## ASIA

China · Hong Kong · India · Philippines  
Israel · Thailand · Indonesia · Malaysia  
Vietnam

## AMERICA

U.S.A · Canada · Brazil · Argentina · Mexico  
Venezuela · Costa Rica · Colombia

Experience Your **SMART FACTORY**

# Hanwha Machine Tool

CNC Swiss Turning Lathe

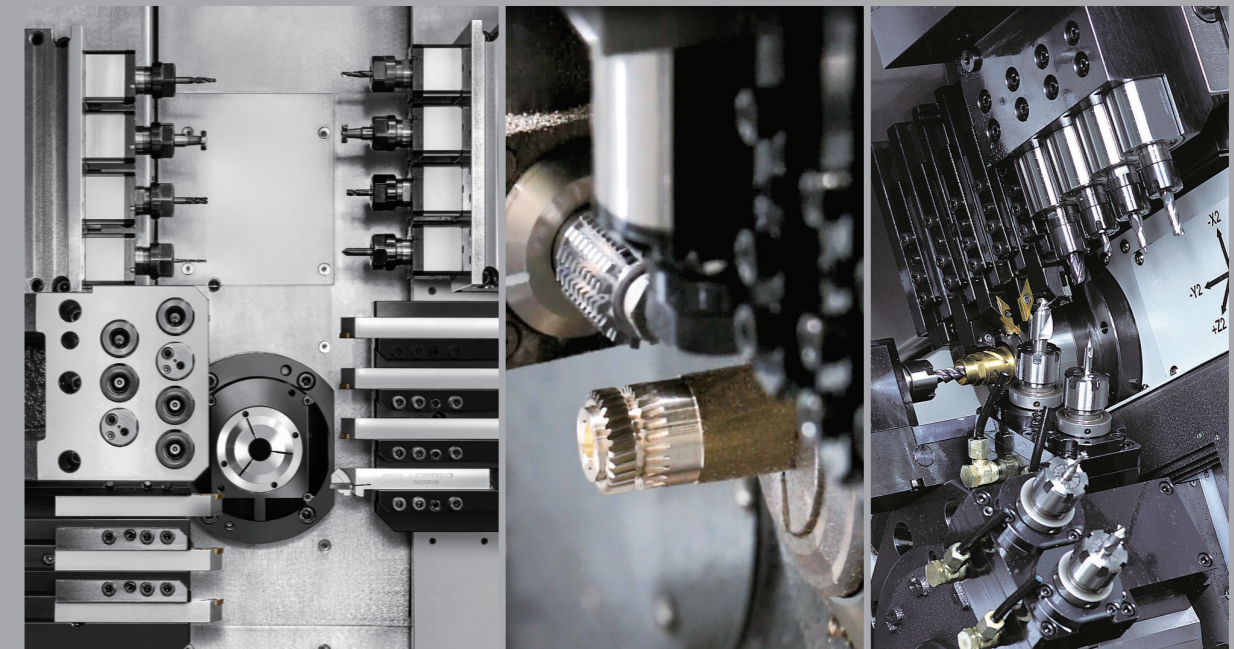

2021. Apr © 2021 Hanwha Precision Machinery Co., Ltd. All rights reserved.



# Enjoy Total Engineering Solution

After starting the machine tool business in 1977, Hanwha Precision Machinery has become a leading worldwide Smart Factory solutions provider, offering Surface Mount Technology (SMT) mounters, Machine Tool, industrial automation equipment, and integrated software solutions. We do this to develop customer-oriented solutions that deliver greater efficiency, versatility and value.

## Machine Tool Division

### CNC Swiss turning Lathe

Offers customized solutions with a wide range of line-up for automatic lathes in gang & turret type.

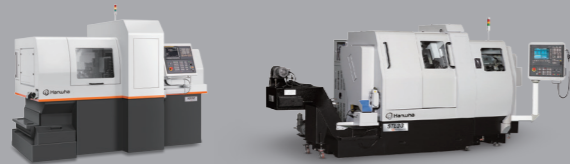

## Surface Mounter Technology Division

### Chip Mounter • Screen Printer • Semiconductor Equipment

After developing its first chip mounter, offers SMT mounters, semiconductor equipment, industrial automation equipment and software solutions.

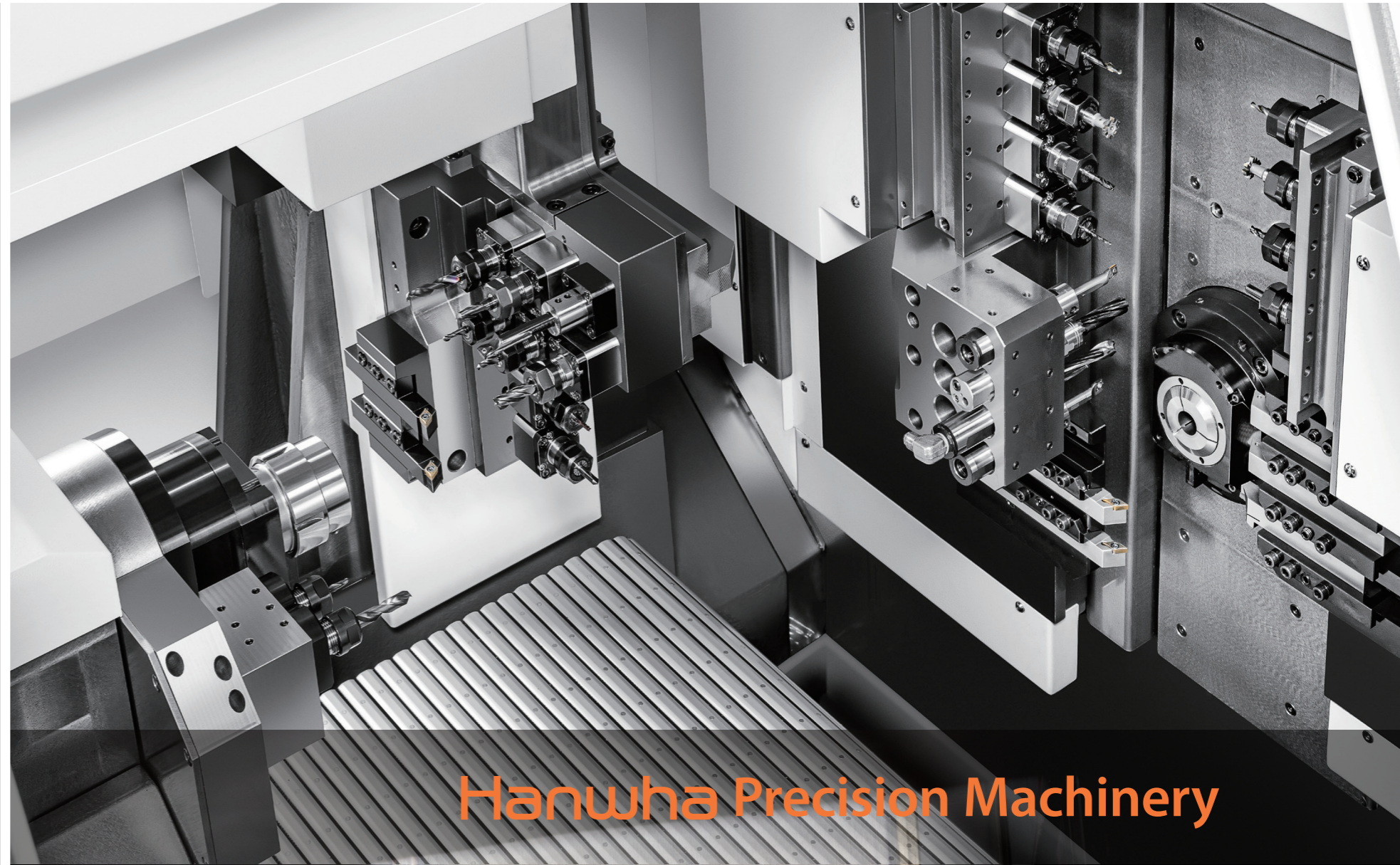

Hanwha Precision Machinery

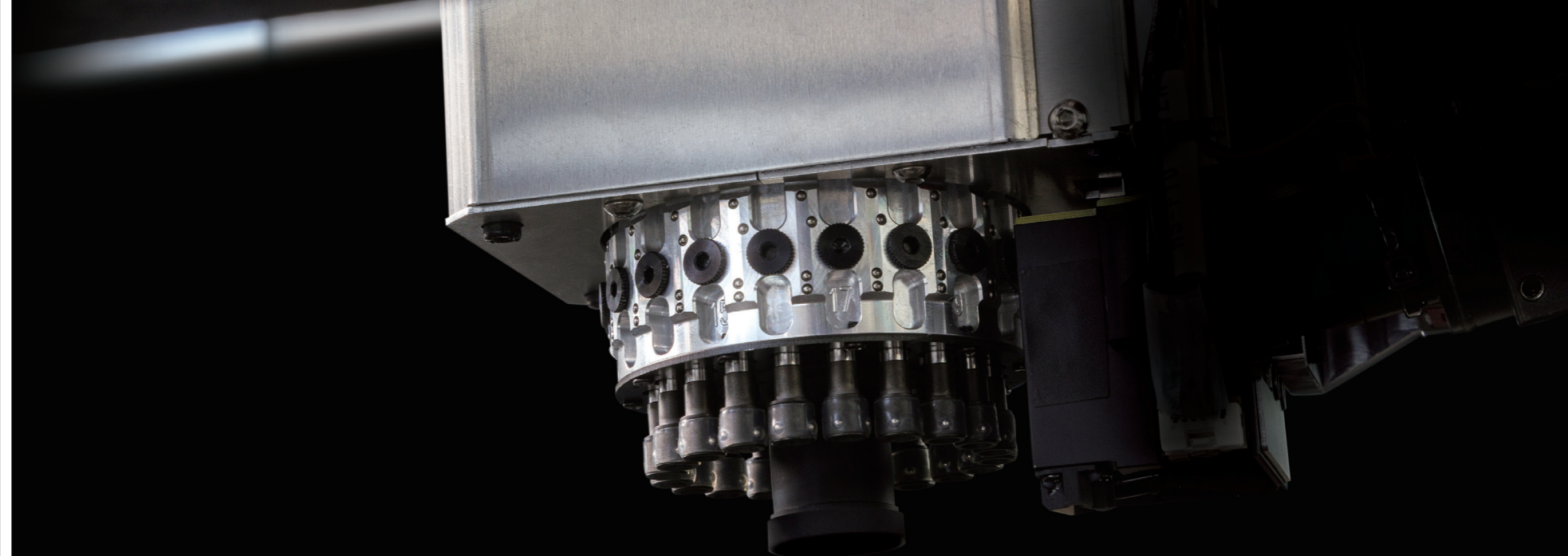

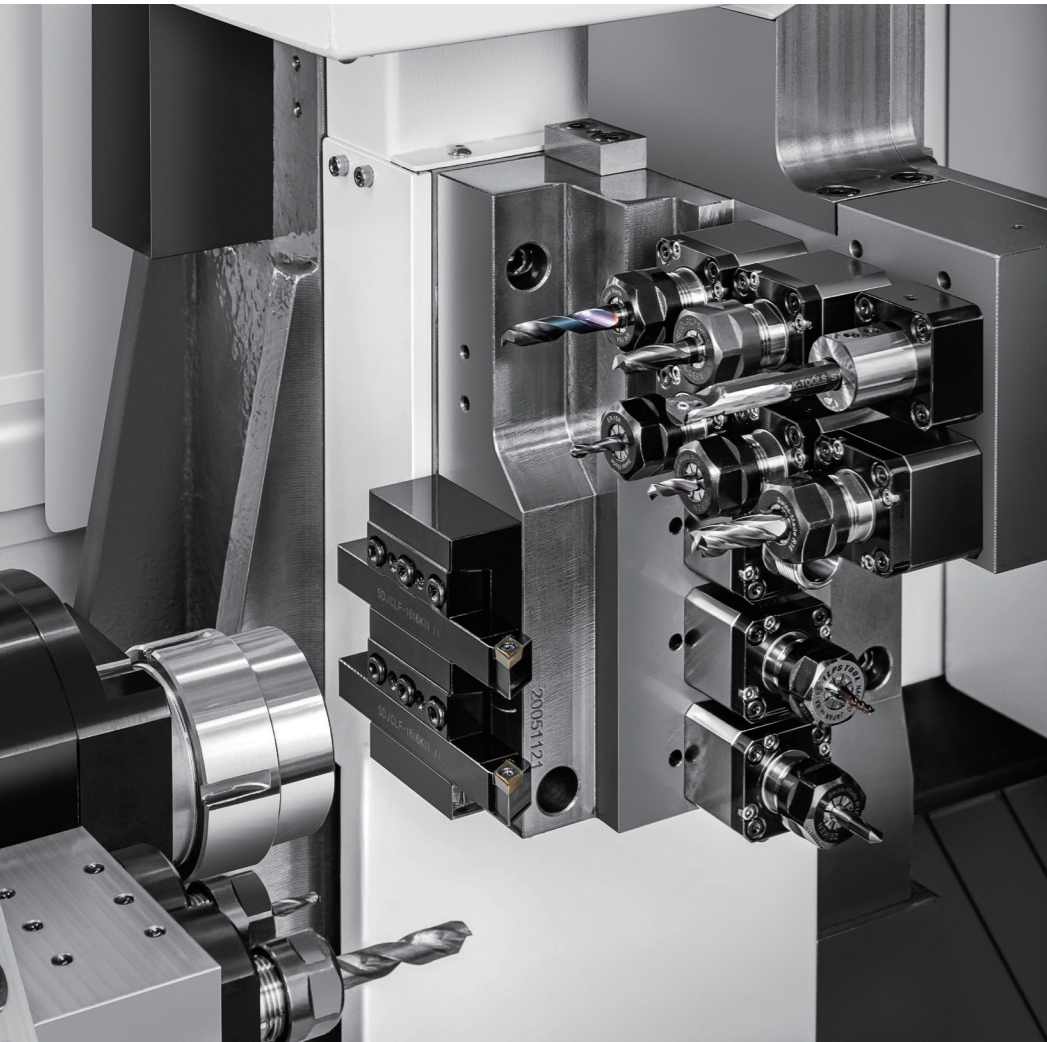

## CNC Swiss Turning Lathe

Provides the best customized machining solution with a wide range of line-up from Ø10mm to Ø42mm and various options

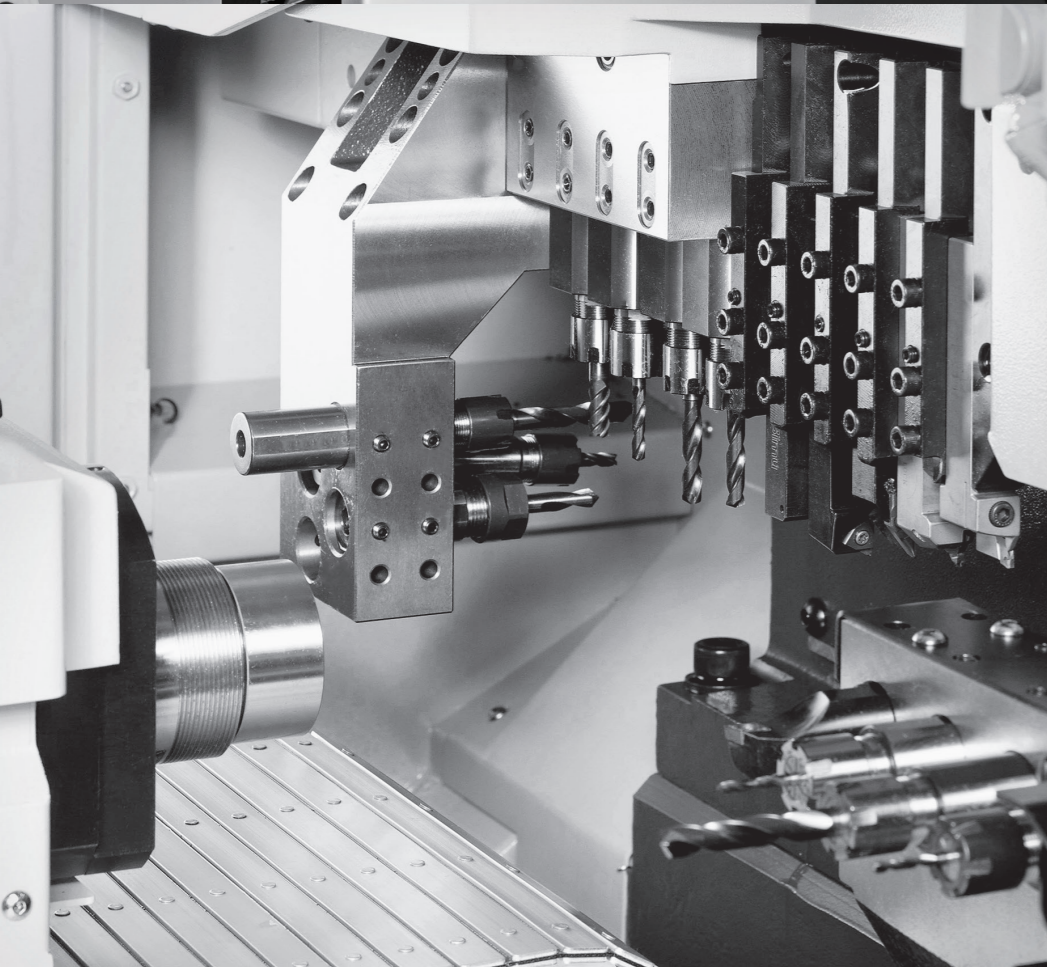

# Machine Tool Division

## Turning forward to the Future

Starting the machine tool business 1977 and developing its first CNC Swiss turning machine in 1998, Hanwha machine tool division has been focusing on product development to best fit customer's various needs and resulted in a wide range of line-up of excellent gang & turret type series. We, as a leading Swiss turning solution provider, will continue to strive to reach the top position in the machine tool business, accelerating our innovation and growth based on our +50 years of business experience and ever-expanding Hanwha global network.

## To be the Global No.

Exports to more than **30 countries** in the world



- **2021**  
3-path 9 axis swiss turn, XDI 26/32
- **2020**  
High-complex turret type, STL42  
High-productive model, XD10
- **2010**
  - 2019 XD38II-R, heavy duty cutting model
  - Established Europe technical center in Germany
  - 2018 Hi-CPS, Smart Factory MES system
  - XD20/26II-V, high complex model
  - 2016 Upgraded line-up; XD-II, XE series
  - XD12/16III, XD42
  - 2014 Established Hanwha machinery Suzhou in China
  - Opened Stuttgart office in Germany
  - 2010 XD07, compact and precise machine
- **2000**
  - 2008 Opened Milwaukee office in U.S.A
  - 2006 XD20N, the first non-guide bush type CNC automatic lathe in Korea
  - XD32/35 series
  - 2005 XP series, 4-axis CNC automatic lathe
  - 2004 Opened Suzhou office in China
  - XD20H, CNC automatic lathe
- **1990**
  - 1998 ML series, the first CNC automatic lathe in Korea
  - 1994 Centerless grinding machine KCG-200J
  - 1992 The first internal grinding machine
- **1983**  
SAL-10, the first cam type lathe in Korea
- **1977**  
Started machine tool business



# XDI 26/32

3-path 9 axis independent opposite gang tool machine for high productivity & flexible machining

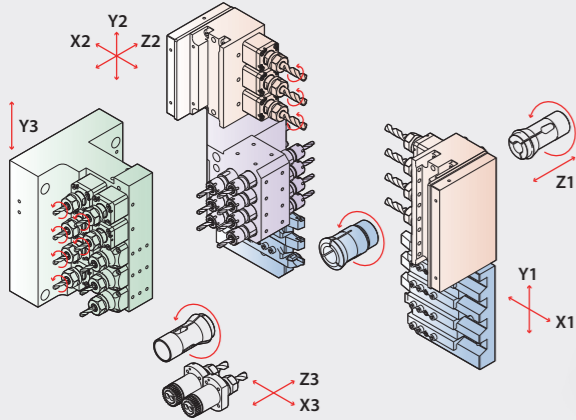

Model	XDI 26	XDI 32
NC	Fanuc – 31iB	
Max. machining diameter (mm)	Ø26	Ø32
Z1 Stroke / NH (mm)	350 (H), 100 (N)	
Main spindle	Speed (rpm)	8,000
	Motor (kW)	2.2 / 5.5
Turning tool	No. of tools	□ 16mm x 7 (4 + 3)
Front tool	No. of tools	ER16M x 4 (Front 4 / Rear 7)
	No. of tools	ER16 x 7 (4 + 3)
Cross drill	Speed (rpm)	6,000
	Motor (kW)	1.0
	Motor (kW)	2.2
B-axis cross (op.)	No. of tools	ER16 x 4 (Front 4 / Rear 4)
	Speed (rpm)	6,000
	Motor (kW)	1.0
Sub spindle	Speed (rpm)	8,000
	Motor (kW)	2.2 / 5.5
Back tool	No. of tools	ER16 x 9 (Fixed 3 + Driven 6) (Option : Driven 6 + Cross 3 + Turning 2)
	Speed (rpm)	6,000
	Motor (kW)	1.0
Machine size (L x W x H) (mm)	2,910 x 1,710 x 2,010	
Weight (kg)	6,300	
Power consumption (Cable size)	34.7 KVA, 28.8 KW (VCTF16SQ x 4C)	37.4 KVA, 31.2 KW (VCTF16SQ x 4C)
Air flow rate (Liter/Min)	120 ~ 150	

## VARIOUS SIMULTANEOUS MACHINING

Reduced cutting time by simultaneous machining capacity with balance turning, drilling and milling

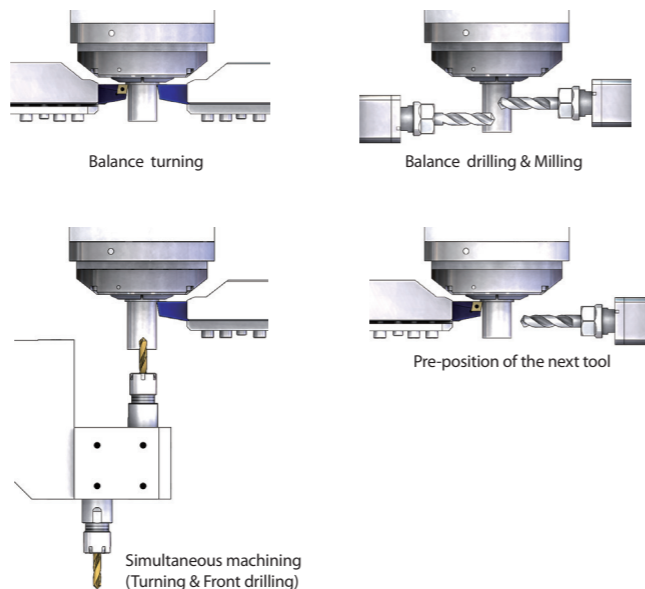

## DIMENSION

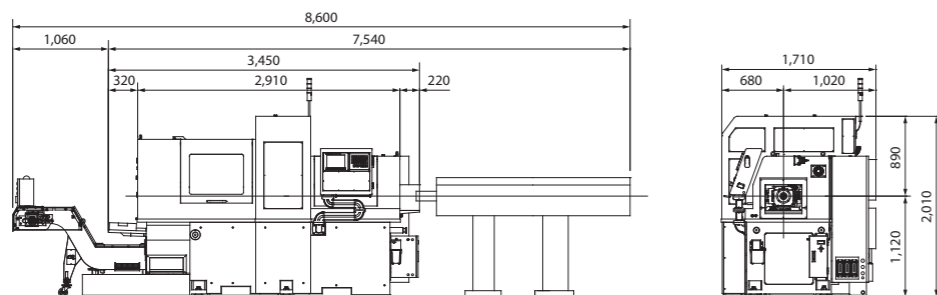

## Option Tooling

Providing variable option tools for the flexible machining

### Cross Drilling / Milling Unit

- Cross drill / Double-hinged B-axis tool

#### Option Specification

- 4 cross drill (ER16, 1kW or 2.2 kW)
- The same cross modular with XD38II

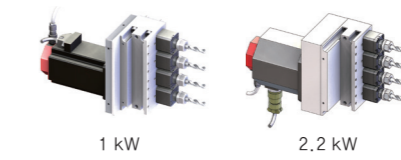

- Double-hinged B-axis tool (ER16x8, Front 4/Back 4)
- Motor power : 1.0 kW
- Swivel angle : -40°~+100°

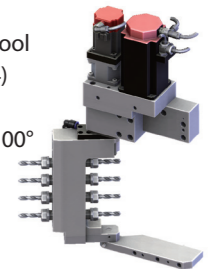

### Back Tool Unit

- Y3-axis 9 back tool / Y3-axis back tool cross

#### Option Specification

- Standard 9 back tool
- 6 Driven/3 Fixed Modular (ER16)
- Motor power : 1.0 kW
- The same back tool modular with XD38II
- Whole gear driven system

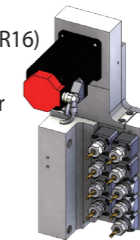

- Option Y3-axis back tool cross
- 6 Back(Driven) /3 Cross Modular (ER16)
- Motor power : 1.0 kW
- The same back tool modular with XD38II
- Whole gear driven system

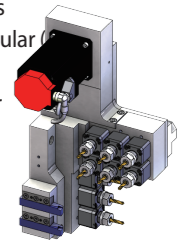

### Sub Off-center & Gun Drill Unit

- 2 off-center drills / 2 gun drills

#### Option Specification

- 2 off-center drill modular (ER16)
- Motor power : 2.2/5.5 kW
- The same off-center drill modular with XD26II-V



- 2 gun drill (ER16)
- Max. drill length 190 mm

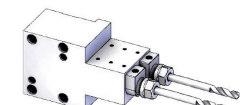
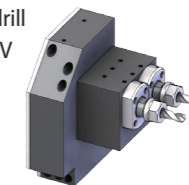

## Standard

- Main - Sub Cs control (0.001°)
- Rotary Guide bush holder
- Cross drilling · milling unit
- 2 MPG
- Door interlock
- Coolant flow sensor
- Work light
- Signal lamp (3color)
- LAN port
- Tool monitoring function
- Cut off detector (S/W)
- Super imposed control
- Auto power off
- Bar feeder interface
- Part conveyor

## Option

- Bar feeder
- Chip conveyor
- Extended coolant tank
- Transformer
- Tap breakage detector
- Pipe type ejection unit
- B-axis cross drill unit(4)
- Off-center drill unit(2)
- Gun drill unit(2)
- Cross turning back tool post
- Middle / High pressure pump
- Oil mist collector
- Oil chiller
- Memory card
- Tooling & Programming
- Additional M-code
- Helical interpolation
- 3 dimension conversion
- NC warranty for 2 years

# XD42

Specialized 5/6-axis for larger dia. machining (42mm)

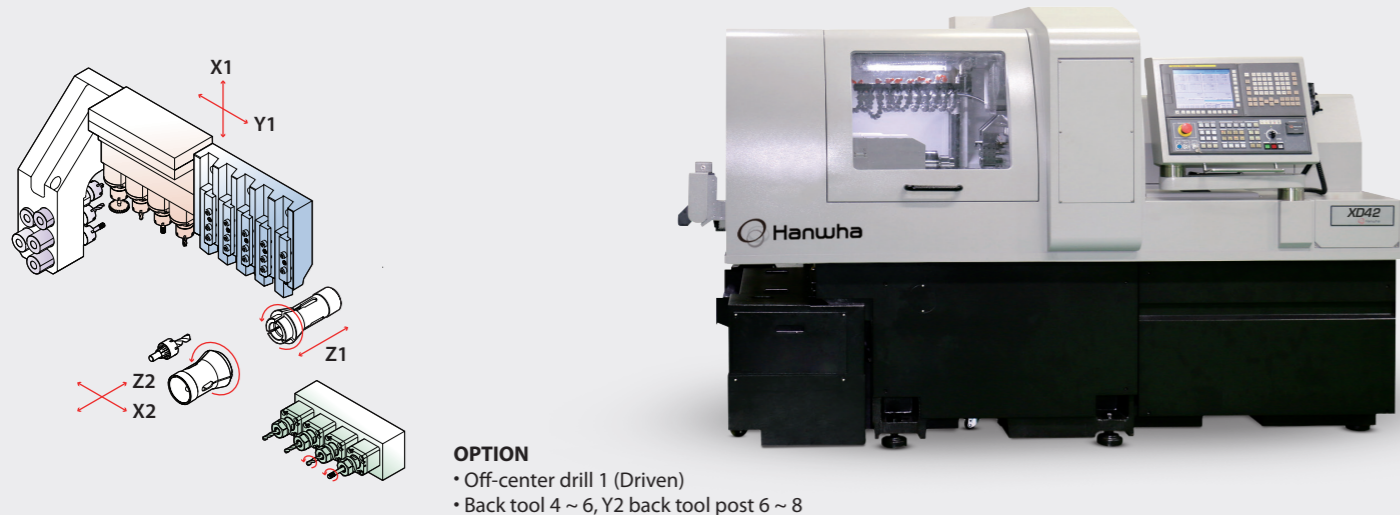

Model	XD42		
	H	NH	N
NC	Hanwha Fanuc-i		
Max. machining diameter (mm)	Ø42		
Z1 Stroke (mm)	320	207 (H), 100 (N)	100
Main spindle	Speed (rpm)	6,000	
	Motor (kW)	5.5/7.5	
OD tool	No. of tools	5 (□20mm)	
Front tool	No. of tools	5 (ER20M, Ø32)	
	No. of tools	4 (ER20M)	
Cross drill	Speed (rpm)	6,000	
	Motor (kW)	2.2	
Off-center drill (Option)	No. of tools	1 (ER20M)	
	type	Gear drive (Modular type drill)	
Sub spindle	Speed (rpm)	6,000	
	Motor (kW)	2.2/5.5	
Back tool	No. of tools	5 (ER20M) (3 Fixed + 2 Driven)	
	Speed (rpm)	6,000	
	Motor (kW)	1.0	
Machine size (L x W x H) (mm)	2,570 x 1,750 x 1,750		
Weight (kg)	4,100		
Power consumption (Cable size)	25kVA, 16.7kW (VCTF 16SQ x 4C)		
Air flow rate (Liter/Min)	120 ~ 150		

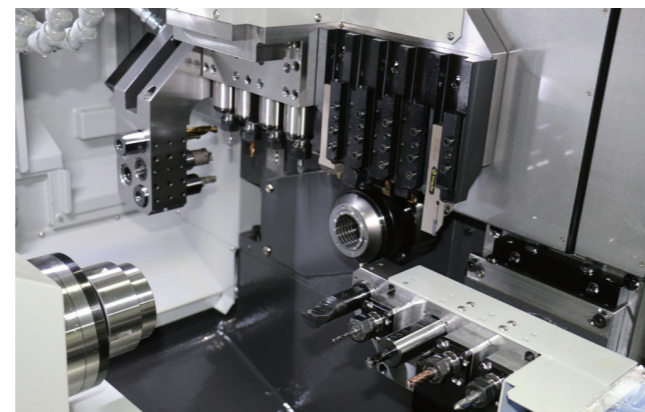

- Strong machining performance & high-productivity for large bore material
- Strong chucking force with hydraulic cylinder
- Improved bearing system for accuracy
- High rigidity of feed unit (Adopted linear roller guide)

\* H : G/B, N : Non-G/B, NH : Convertible G/B

## Dimension

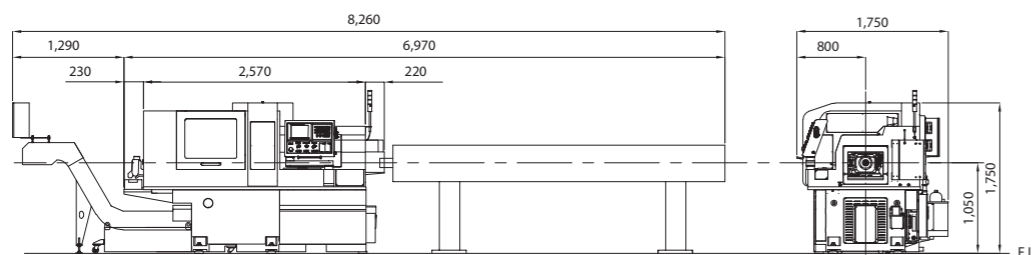

## Option Tooling

Offers various and flexible toolings for enhancing productivity and covering a variety of customer's needs

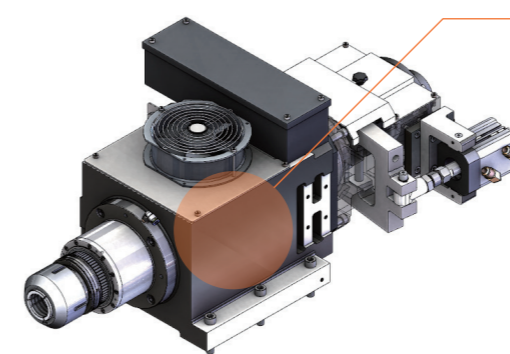

### Spindle Unit

- Adopted built-in motor, hydraulic chucking cylinder & 3 toggle system for strong chucking power for Ø42mm material

#### Specification

6,000rpm  
5.5/7.5kW (20 ~ 49Nm)

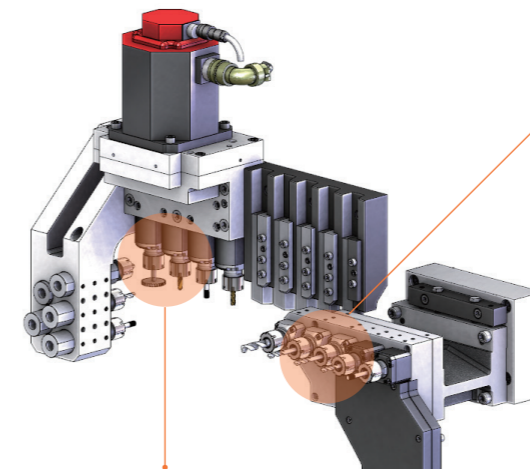

### Back Tool Unit

- A total of 8 tools with Y2-axis and modular type for easy tool change / maintenance

#### Specification

6,000rpm, 1.0kW (3 ~ 7.5Nm)  
5 tools (ER20M)

#### Option tool



### Cross Drilling / Milling Unit

- Powerful cross machining with upper size of tools and the best-in-class motor
- Cross unit with gear modular type as standard for various tooling and easy tool change / maintenance

#### Specification

6,000rpm, 2.2kW (8 ~ 22Nm)  
4 tools (ER20M)

#### Selectable modules of back tool

Driven max.4

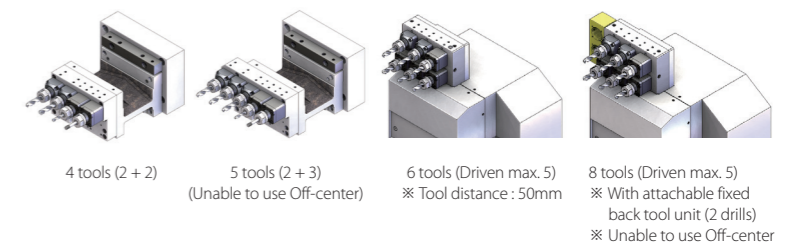

## Standard

- Main - Sub Cs control (0.001°)
- Rotary Guide bush holder
- Cross drilling · milling unit (4, Gear modular type)
- MPG
- Part conveyor
- Door interlock
- Coolant flow sensor
- Work light
- Signal lamp (3color)
- LAN port
- Tool monitoring function
- Cut off tool breakage detector (S/W)
- Auto power off
- Bar feeder interface

## Option

- Bar feeder
- Chip conveyor
- Transformer
- Tap breakage detector
- Pipe type ejection unit
- Off center drill unit (2)
- Middle / High pressure pump
- Oil mist collector
- Oil chiller
- Memory card
- Tooling & Programming
- Internal coolant driven tool (cross, back, off-center)
- 3 Face/counterface driven tool (cross)
- 3 Face/counterface angle driven tool (cross)
- Extended coolant tank
- NC warranty for 2 years

# XD38II-R

The latest 5/6-axis, specialized in heavy duty cutting/milling of max. dia. 38mm

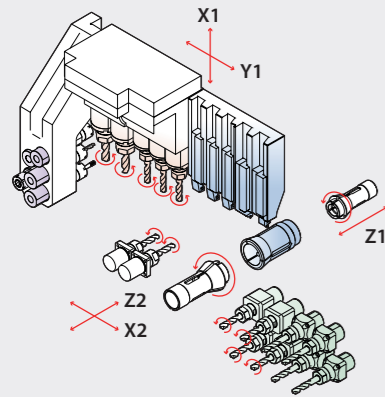

- OPTION**
- Off-center drill 2 (Driven, Fixed)
  - Cross 6
  - Y2 back tool cross unit (Max. Cross 2)



Model	XD38II-R	
NC	Fanuc 32i-B / Siemens 828D	
Max. machining diameter (mm)	Ø38 (Option : Ø40)	
Z1 Stroke (mm)	320 (H), 120 (N)	
Main spindle	Speed (rpm)	6,500
	Motor (kW)	5.5/7.5 (Fanuc), 23 (Siemens)
OD tool	No. of tools	5 (□20mm x 2, □16mm x 3)
	No. of tools	5 (ER20M, Ø32)
Cross drill	No. of tools	5 (ER20 x 2, ER16 x 3)
	Speed (rpm)	6,000
Off-center drill (Option)	Motor (kW)	2.2 (Fanuc), 2.13 (Siemens)
	No. of tools	2 (ER16) Modular
Sub spindle	Speed (rpm)	6,500
	Motor (kW)	2.2/5.5 (Fanuc), 23 (Siemens)
Back tool	No. of tools	8 (ER16) (4 Fixed + 4 Driven)
	Speed (rpm)	6,000
Machine size (L x W x H) (mm)	Motor (kW)	1.0 (Fanuc), 1.02 (Siemens)
	Weight (kg)	2,650 x 1,600 x 1,790
Power consumption (Cable size)	4,600	
Air flow rate (Liter/Min)	25kVA (Siemens : 40kVA), 16.7kW (VCTF 16SQ x 4C)	
	120 ~ 150	

\* NH : Convertible G/B

### Specification of G/B & Chuck

Model	XD38II-R		XD38II	
	Fanuc / Siemens	Fanuc	Siemens (※ Production stop)	
NC	Fanuc / Siemens	Fanuc	Siemens (※ Production stop)	
Type	NH	H/N/NH/He	H	N/NH
Guide bush	BRA-42	TD38	BRA-42	
Main chuck	TF48	TF44	TF48	TF44
Sub chuck	TF48	TF44	TF48	

- Enhanced machining performance with optimized structure/layout & widened distance between tools
- Easy switching between G/B & Non G/B and enhanced stroke, rigidity and chip disposal
- Flexible material feeding solution (bar feeder, automation unit and robot)

## Optimized Structure & Spec for Ø38mm

Possible to machine max. Ø40mm (Option)

### Stroke

- Extended stroke to cover various & flexible processing
- Widened distance between tools
- Upper size of tools
- Extended stroke of Z1 for convertible type of G/B (G/B : 205mm → 320mm, Non-G/B : 80mm → 120mm)

Z1	X1	Y1	Z2	X2	Y2
320 (G/B) 120 (Non-G/B)	80	467 (+55*)	350 (+70*)	450 (+55*)	67.7

\* : increased stroke compared to XD38II

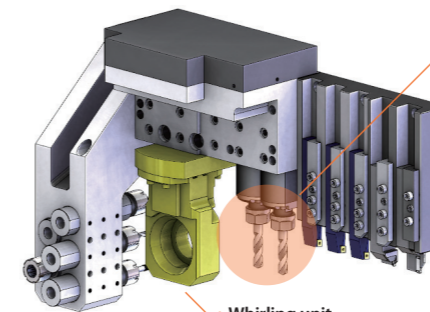

Whirling unit  
※ Other various option units are available

### Cross Drilling / Milling Unit

- Powerful cross machining
- Adopted the best-in-class motor (Capacity : Fanuc 2.2kW, Siemens 2.13kW)
- Gear driven modular
- Gear modular type as standard for various tooling and easy tool change / maintenance

#### Specification

6,000rpm, 2.2kW(Fanuc), 2.13kW(Siemens)  
5 tools (ER20 x 2, ER16 x 3)

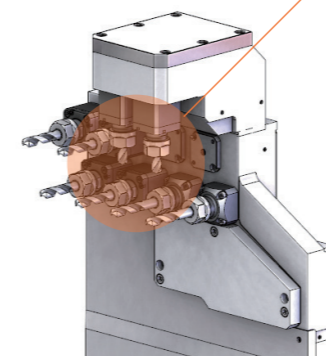

### Back Tool Unit

- Optimized structure for machining large bore material
- Extended tooling layout (Distance between tools : 52mm)
- Various option toolings are available
- Less chip trouble structure

#### Specification

6,000rpm, 1.0kW(Fanuc), 1.02kW(Siemens)  
8 tools (4 Driven + 4 Fixed)

#### Option tool



### Dimension

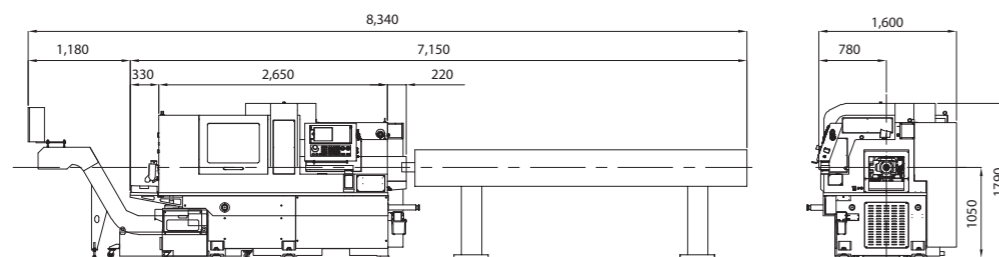

### Standard

- Main - Sub Cs control (0.001°)
- Rotary Guide bush holder
- Cross drilling · milling unit (5, Gear modular type)
- MPG
- Part conveyor
- Door interlock
- Coolant flow sensor
- Work light
- Signal lamp (3color)
- LAN port
- Tool monitoring function
- Cut off tool breakage detector (S/W)
- Auto power off
- Bar feeder interface

### Option

- Bar feeder
- Chip conveyor
- Right-way part conveyor
- Transformer
- Tap breakage detector
- Pipe type ejection unit
- Off center drill unit (2)
- Middle / High pressure pump
- Oil mist collector
- Oil chiller
- Memory card
- Tooling & Programming
- Internal coolant driven tool (cross, back, off-center)
- 3 Face/counterface driven tool (cross)
- 3 Face/counterface angle driven tool (cross)
- Extended coolant tank
- NC warranty for 2 years

# XD38II

Specialized 5/6/7-axis model for heavy duty cutting / milling

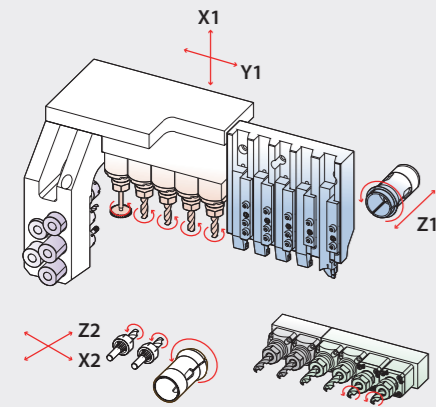

- OPTION**
- Off-center drill 2 (Driven, Fixed)
  - Cross 6
  - B-axis tool post 6 (Front 3 + Back 3)
  - Back tool 4 ~ 6
  - Y2 back tool cross unit (Max. Cross 2)



Model	XD32/38II			
	H	N	NH	He
NC	Fanuc 32i-B			Hanwha Fanuc-i
Max. machining diameter (mm)	Ø32/38			
Z1 Stroke (mm)	320	80	142 (H), 80 (N)	320
Main spindle	Speed (rpm)	6,500		
	Motor (kW)	5.5/7.5		
OD tool	No. of tools	5 (□16mm)		
	No. of tools	5 (ER20M, Ø32)		
Cross drill	No. of tools	5 (ER16)		
	Speed (rpm)	6,000		
Off-center drill (Option)	No. of tools	2 (ER16) Modular	2 (ER16) Non-modular	
	type	Motor drive (6,000rpm, 1.0kW)	Gear drive	
Sub spindle	Speed (rpm)	6,500 (Built-in motor)	6,500 (Spindle motor)	
	Motor (kW)	2.2/5.5	1.1/3.7	
Back tool	No. of tools	6 (ER16) (4 Fixed + 2 Driven)	4 (ER16) (2 Fixed + 2 Driven)	
	Speed (rpm)	6,000		
Machine size (L x W x H) (mm)	Weight (kg)	1.0		
	Power consumption (Cable size)	2,570 x 1,440 x 1,740		
Air flow rate (Liter/Min)	Weight (kg)	3,600		
	Power consumption (Cable size)	25kVA, 16.7kW (VCTF 16SQ x 4C)		
Air flow rate (Liter/Min)	120 ~ 150			

\* H : G/B, N : Non-G/B, NH : Convertible G/B, He : Hanwha Fanuc-i NC (with G/B)

## Dimension

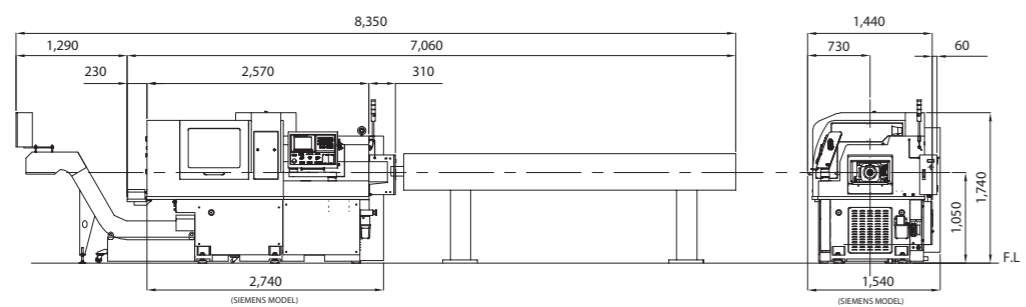

## TOOLING VARIATION

- Y2 Back tool 8 (Driven max. 8)
- Off-center drill (Driven) 2

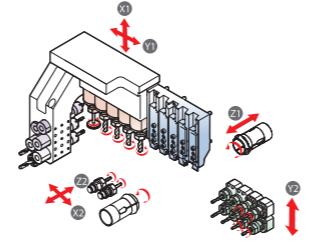

- B-axis tool post 6 (Front 3 + Back 3)

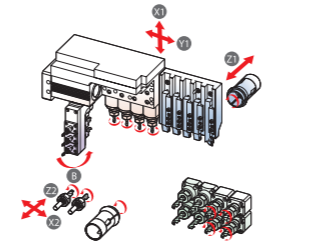

## Option Tooling

Various tooling options & sub-spindle type are offered for high-quality performance depending on product & machining condition

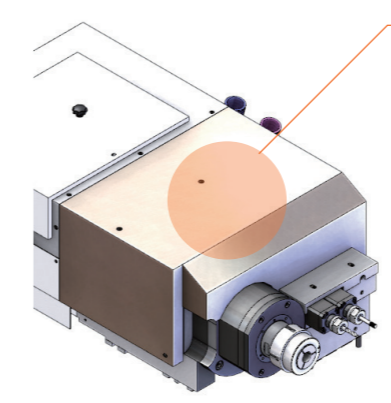

### Sub Spindle Unit

- Built-in motor for powerful cutting and spindle motor for high productivity are both available
- ※ Choose a right type of motor to generate the best performance depending on processing material and condition

Sub spindle		Spec	
Max. machining diameter		Ø38 mm	
Rotating speed		6,500 rpm	
Motor spec	Built-in motor	Fanuc 32i-B	2.2/5.5kW, 20/49Nm
	Spindle motor	Hanwha Fanuc-i	1.1/3.7kW, 7/28Nm

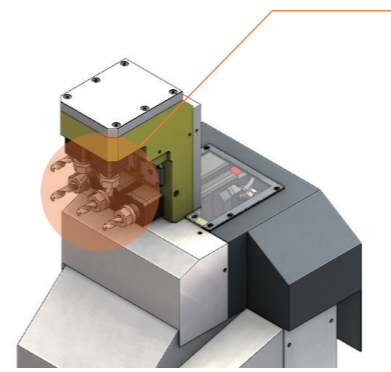

### Back Tool Unit

- A total of 8 tools with Y2-axis and modular type for easy tool change / maintenance

#### Option unit

**Attachable fixed drill unit**  
Off-center can be available with 1 drill unit

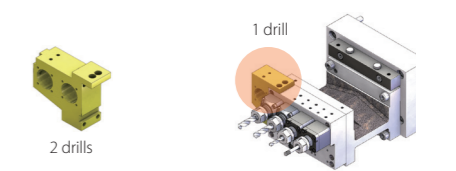

#### Option tool

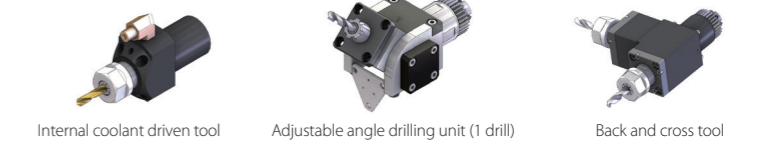

#### Selectable modules of back tool

Driven max. 4

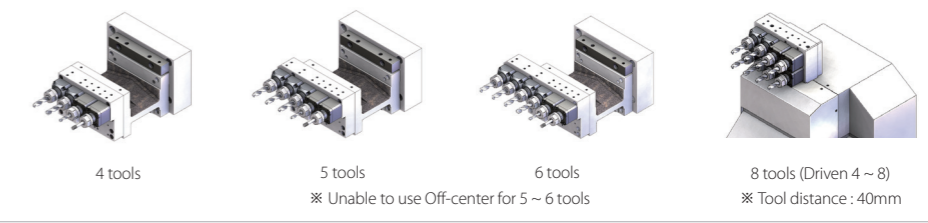

## Standard

- Main-Sub Cs control (0.001°)
- Rotary Guide bush holder
- Cross drilling · milling unit (5, Gear modular type)
- MPG
- Part conveyor
- Door interlock
- Coolant flow sensor
- Work light
- Signal lamp (3color)
- LAN port
- Tool monitoring function
- Cut off tool breakage detector (S/W)
- Auto power off
- Bar feeder interface

## Option

- Bar feeder
- Chip conveyor
- Transformer
- Tap breakage detector
- Pipe type ejection unit
- Off center drill unit (2)
- Middle / High pressure pump
- Oil mist collector
- Oil chiller
- Memory card
- Tooling & Programming
- Internal coolant driven tool (cross, back, off-center)
- 3 Face/counterface driven tool (cross)
- 3 Face/counterface angle driven tool (cross)
- Extended coolant tank
- NC warranty for 2 years



# XD20/26II

The best selling 5-axis for max. dia. 20/26mm



- OPTION**
- Off-center drill 2 (Driven, Fixed)
  - Cross drill 5 ~ 6
  - Back tool 5 ~ 6

Model	XD20/26II			
	H	N	NH	M
NC	Fanuc 32i-B / Siemens 828D			
Max. machining diameter (mm)	Ø20/Ø26			
Z1 Stroke (mm)	210 (Fanuc), 240 (Siemens)	60mm	160 (H), 50 (N)	210
Main spindle	Speed (rpm)	10,000 (Ø20), 8,000 (Ø26)		
	Motor (kW)	Fanuc : 2.2/3.7 (Ø20), 2.2/5.5 (Ø26) Siemens : 14.4		
OD tool	No. of tools	6 (□12mm) (Ø20), 5 (□16mm) (Ø26)		5 (□12mm)
Front tool	No. of tools	5 (ER16M, Ø25)		
Cross drill	No. of tools	4 (ER16 (Ø20), ER16M (Ø26))		5 (ER16M)
	Speed (rpm)	6,000		
Off-center drill (Option)	Motor (kW)	Fanuc : 1.0, Siemens : 1.02		
	No. of tools	2 (ER16) Driven	2 (ER16M) Fixed long drill	
Sub spindle	Speed (rpm)	8,000		
	Motor (kW)	Fanuc : 1.5/2.2, Siemens : 2.59		
Back tool	No. of tools	4 (ER16) (2 Fixed + 2 Driven)		
	Speed (rpm)	6,000		
Machine size (L x W x H) (mm)	Motor (kW)	Fanuc : 1.0, Siemens : 1.02		
	Weight (kg)	2,260 x 1,230 x 1,710		
Power consumption (Cable size)	15kVA, 10kW (VCTF 105Q x 4C)			
Air flow rate (Liter/Min)	120 ~ 150			



- Maximized tooling capability with a variety of customized options
- The best-suited for high precision and accuracy

\* H : G/B, N : Non-G/B, NH : Convertible G/B, M : Cross 5-axis+Long drills

## Dimension

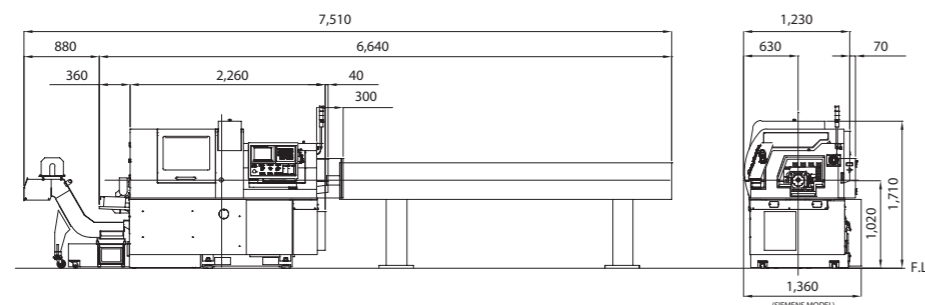

## Option Tooling

Offers various and flexible toolings for enhancing productivity and covering a variety of customer's needs

**Option Tool Layout**

**Cross unit 4** (standard)

- OD 6 (□12), Cross 4 (ER16), Front 5 (ER16M)

**Cross unit 5**

- OD 5 (□16), Cross 5 (ER16M), Front 3 (ER16M)

**Cross unit 6**

- OD 6 (□16 x 1, □11 x 5), Cross 6 (ER11M x 2, ER16 x 4)

**Back Tool Unit**

- A total of 6 tools as an option and modular type for easy tool change / maintenance

**Option unit**

Attachable fixed drill unit

**Option tool**

Internal coolant driven tool

**Back and cross tool**

Back and cross tool

**Burr removal**

Burr removal

**Selectable modules of back tool**  
Driven max. 4

4 tools

5 tools

6 tools

※ Unable to use Off-center for 5 ~ 6 tools

**Off-Center Unit**

- Sub spindle unit provides 2 driven drills or 2 fixed long drills for deep hole machining (option)

**Option tool**

Long drill

Internal coolant driven tool

Tailstock

## Standard

- Main-Sub Cs control (0.001°)
- Rotary Guide bush holder
- Cross drilling · milling unit (4, Gear modular type)
- MPG
- Part conveyor
- Door interlock
- Coolant flow sensor
- Work light
- Signal lamp (3color)
- LAN port
- Tool monitoring function
- Cut off tool breakage detector (S/W)
- Auto power off
- Bar feeder interface

## Option

- Bar feeder
- Chip conveyor
- Transformer
- Tap breakage detector
- Pipe type ejection unit
- Off center drill unit (2)
- Middle / High pressure pump
- Oil mist collector
- Oil chiller
- Memory card
- Tooling & Programming
- Internal coolant driven tool (cross, back, off-center)
- 3 Face/counterface driven tool (cross)
- 3 Face/counterface angle driven tool (cross)
- Extended coolant tank
- NC warranty for 2 years

# XD16III

High-speed 5-axis solution for max. dia. 16mm

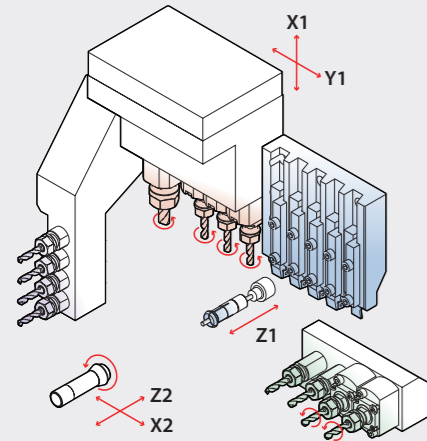

- OPTION**
- Long drill 1 (Fixed)
  - Back tool 4 ~ 5
- ※ Cross(standard) : Non-modular type with single body



# XD10

High productivity & precision 5/6-axis solution for max. dia. 10mm

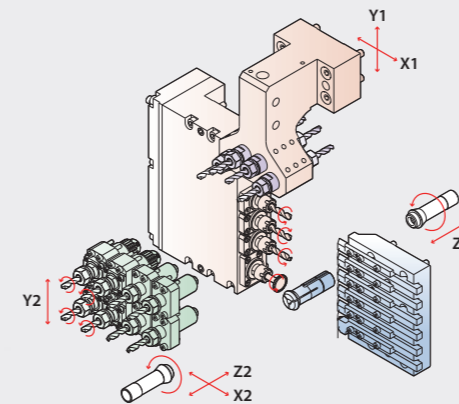

Model	XD16III	
	H	J
NC	Hanwha Fanuc-i	
Max. machining diameter (mm)	Ø16	
Z1 Stroke (mm)	155	
Main spindle	Speed (rpm)	15,000
	Motor (kW)	2.2/3.7
OD tool	No. of tools	5 (□12mm)
Front tool	No. of tools	4 (ER11, Ø20)
	No. of tools	4 (ER11 x 3 + ER16 x 1)
Cross drill	Speed (rpm)	6,000(ER16), 9,000(ER11)
	Motor (kW)	1.0
Long drill (Option)	No. of tools	1 (ER11) drilling depth : 76.5mm
	Speed (rpm)	10,000
Sub spindle	Motor (kW)	0.55/1.1
	No. of tools	4 (ER11) (2 Fixed + 2 Driven)
Back tool	Speed (rpm)	9,000
	Motor (kW)	1.0
	No. of tools	4 (ER11) (4 Fixed)
Machine size (L x W x H) (mm)	1,700 x 1,190 x 1,670	
Weight (kg)	2,200	
Power consumption (Cable size)	15kVA, 10kW (VCTF 10SQ x 4C)	
Air flow rate (Liter/Min)	120 ~ 150	

\* H : G/B & Driven back tool(2), J : G/B & Fixed back tool

## OPTION TOOLING

**Cross unit 4 (modular 1)**  
- ER11 x 3, Modular ER16 x 1  
※ Standard cross : Non-modular

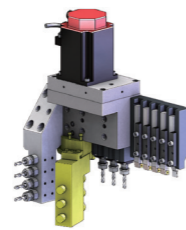

**Cross unit 5 (modular 2)**  
- ER11 x 3, Modular ER16 x 2

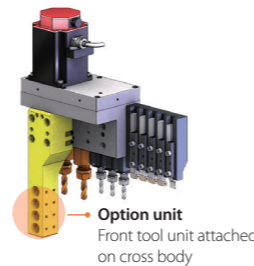

- Fast cycle time
- High speed of spindle (Main : 15,000 rpm, Sub : 10,000 rpm)
- Great machining performance with strong motor power for back tool (Capacity : 1.0 kW)

## Dimension

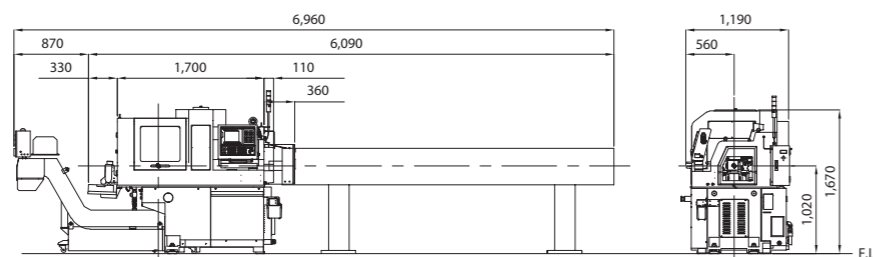

Model	XD10	
	Hanwha Fanuc-i	
NC	Hanwha Fanuc-i	
Max. machining diameter (mm)	Ø10	
Z1 Stroke (mm)	155	
Main spindle	Speed (rpm)	15,000
	Motor (kW)	2.2/3.7
Turning tool	No. of tools	□8mm x 6
Front tool	No. of tools	ER11 x 4
	No. of tools	ER11M x 4 (Option: ER11M x 5)
Cross drill	Speed (rpm)	10,000
	Motor (kW)	0.55
Sub spindle	Speed (rpm)	10,000
	Motor (kW)	0.55 / 1.1
Back tool	No. of tools	ER11 x 8 (Y2: Fixed 4 + Driven 4) (Option: Fixed 2 + Driven 2)
	Speed (rpm)	9,000
	Motor (kW)	0.55
Machine size (L x W x H) (mm)	1,810 x 1,150 x 1,770	
Weight (kg)	2,200	
Power consumption (Cable size)	15kVA, 10kW (VCTF 10SQ x 4C)	
Air flow rate (Liter/Min)	120 ~ 150	

## OPTION TOOLING

**Whirling Tool**  
- ER11M x 2,  
Modular Whirling x 1

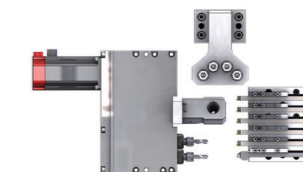

**Cross unit 4 (modular 1)**  
- ER11M x 3,  
Modular ER11M x 1

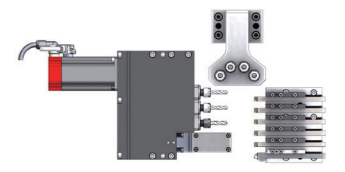

**Back tool 8 (Driven max. 4)**  
- ER11 x 8

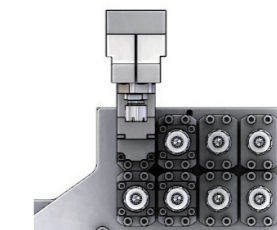

**Back tool 4 (Driven max. 4)**  
- ER11 x 4

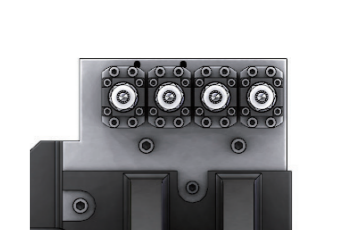

## Dimension

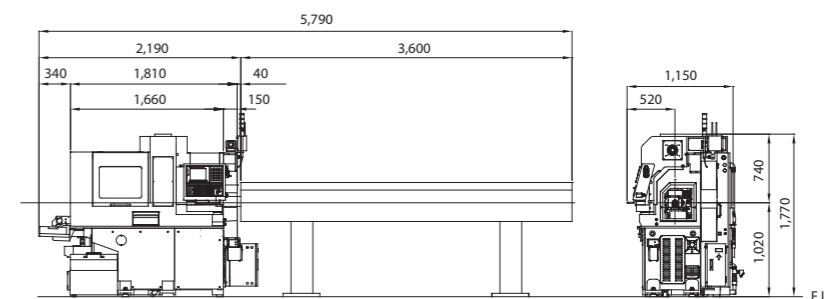

# Options

Customized special option units are available for qualified performance, enhanced productivity and convenience

Standard & Option Accessory		STL series		XDI series	XD series				XD series		XE series		XP series			
		STL42	STL38	XDI 26/32	XD42	XD38II-R	XD38II	XD20/26II-V	XD20/26II	XD16III	XD10	XE35	XE20/26	XP20/26/32S	XP12/16S	
Off-cent unit	Driven(2)	-	-	★	★(1)	★	★	★	★	-	-	★(1)	★	-	-	
	Fixed (long drill, 2)	-	-	★	-	★(1)	★(1)	★	★	★(1)	-	-	★	-	-	
	Off-center Tailstock	-	-	▲	★	★	★	★	★	-	-	★	★	-	-	
Intenal coolant driven unit	Cross	★	★	★	★	★	★	★	★	★(Modular)	▲	★	★	-	-	
	Back	★	★	★	★	★	★	★	★	-	▲	★	★	-	-	
	Off-center	-	-	▲	★	★	★	★	★	-	-	★	★	-	-	
Fixed angle drilling unit	Cross, 1	★	★	★	★	★	★	▲	▲	-	-	▲	▲	-	-	
	Back, 1	★	★	★	★	★	★	▲	▲	-	▲	▲	▲	-	-	
Option tool unit	Triple speed cross drill	★	★	▲	★	★	★	★	★	★(Modular)	▲	★	★	-	-	
	Triple speed reduction cross drill	★	★	▲	★	★	★	★	★	★(Modular)	▲	★	★	-	-	
	3 Face/counterface driven tool	-	-	▲	★	★	★	★	★	-	-	★	★	-	-	
	3 Face/counterface angle driven tool	-	-	▲	★	★	★	★	★	-	-	★	★	-	-	
	Gear hobbing	★(Turret)	★(Turret)	▲	★	★	★	★	★	▲	▲	★	★	-	★	
	Whirling	★	★	▲	★	★	★	★	★	★	-	★	★	-	-	
	Side cutter	★(Turret)	★(Turret)	▲	★	★	★	★	★	★	★	★	★	-	-	
	Back tool cross	Modular(Y2)	-	-	★	★	★	★	★	-	★	-	-	-	-	-
		Single body(Y2)	★(Y3)	-	-	-	★	★	★	★	-	▲	-	-	-	-
		Horizontal	-	-	★	★	★	★	★	-	▲	★	★	-	-	-
Coolant unit	Chiller integrated High pressure coolant pump	★	★	★	★	★	★	★	★	★	★	★	★	★	▲	
	Extended coolant tank	-	-	★	★	★	★	★	★	★	★	★	★	★	★	
Chip conveyor	Standard chip conveyor	-	-	★	★	★	★	★	★	★	★	★	★	★	★	
	Smart chip conveyor	-	-	▲	★	★	★	★	★	-	-	★	-	-	-	
	Lower type chip conveyor	★	★	▲	★	★	★	★	★	★	-	★	★	★	★	

★ : Option ▲ : Discussable - : N/A

# Special Accessories

## Swing Gripper

Gripper fingers to grip and release finished parts on to conveyor belt for ejection

- Applied example : vulnerable material, long parts

• XD20/26II, XD38II, XD42, XE20/26

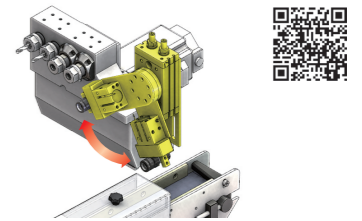

## Parts Auto Loading unit

Auto loader for forged or diecasted parts to supply through main spindle door

• XD20/26II, XD38II, XD42, XE20/26

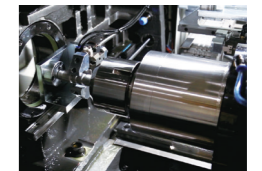

## Auto stacking unit for machined parts

Auto loader for ejected parts onto a stacking pallet

• XD38II



# Tooling Variation

## XD20/26II

- Front/Back Tool
- Cross Drill
- Special Option Tool
- OD Tool

Cross 4

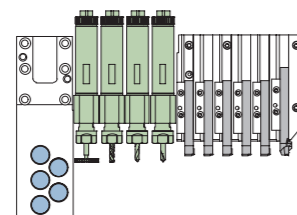

Cross 5

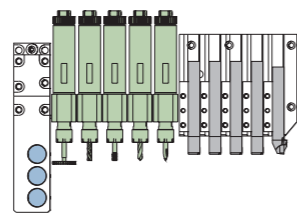

Cross 6

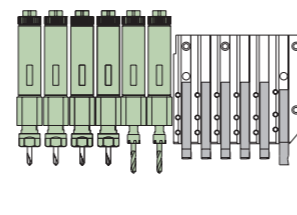

3 Face/counterface angle driven tool

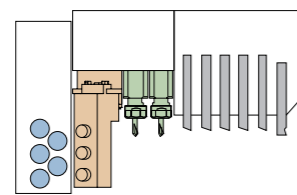

Angle: -20° ~ 0°

3 Face/counterface driven tool

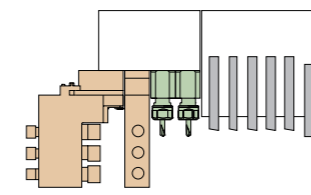

Angle: -90° ~ 0°

3 Face/counterface driven tool

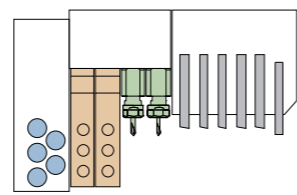

• Back tool : Max. 5 (1 unit applied)  
Max. 4 (2 unit applied)

Whirling

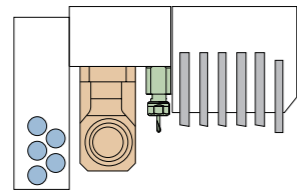

Gear Hobbing

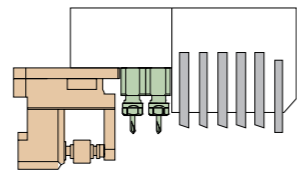

Polygon

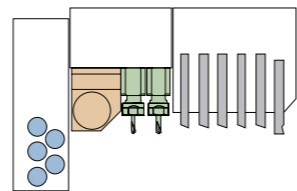

※ When special tool is installed, back tool unit should have max. 4 tools

## XD38II

- Front/Back Tool
- Cross Drill
- Special Option Tool
- OD Tool

Cross 5

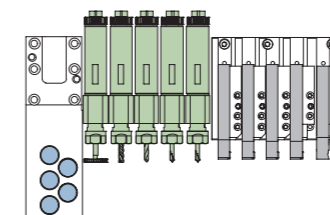

Cross 6

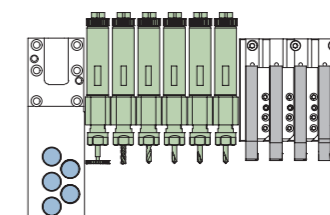

B-axis unit

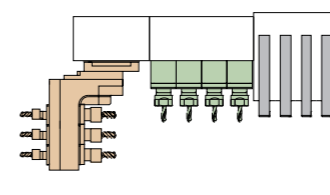

• 3 Face driven tool can be limited the number of back tool

Fixed Angle Drilling

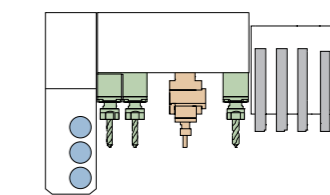

• Angle will be set as per requested

## Back Tool Option Unit (Y2)

### Fixed Angle Drilling

• Angle will be set as per requested

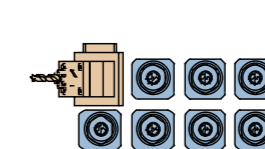

### Back tool cross (Modular, Single body)

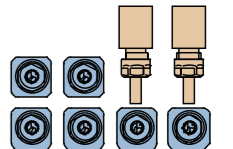

※ When special tool is installed, back tool unit should have max. 4 tools  
※ Back tool option is available for both 6(Y2) and 8(Y2)

# Hi-CPS

## Hanwha Intelligence CNC Prognostic System



Hi-CPS is a kind of smart factory solution to enable customers to manage factory in a smart & convenient way by providing real time onitoring on running status of machines at the facility. It is a cloud-based system so that one can access with ease from anywhere through internet.

### Function

- 1 Monitoring**
  - Monitors machine operation status from PC & Mobile
  - Check machining, repair, alarm, cycle time, etc.
- 2 Diagnosis**
  - Remotely examines alarmed machines at user's online request
  - ※ Only at customer's request, relevant machine data will be auto-transferred to Hanwha for analysis
- 3 Prognosis**
  - Analyzes cutting load, tool change and offset

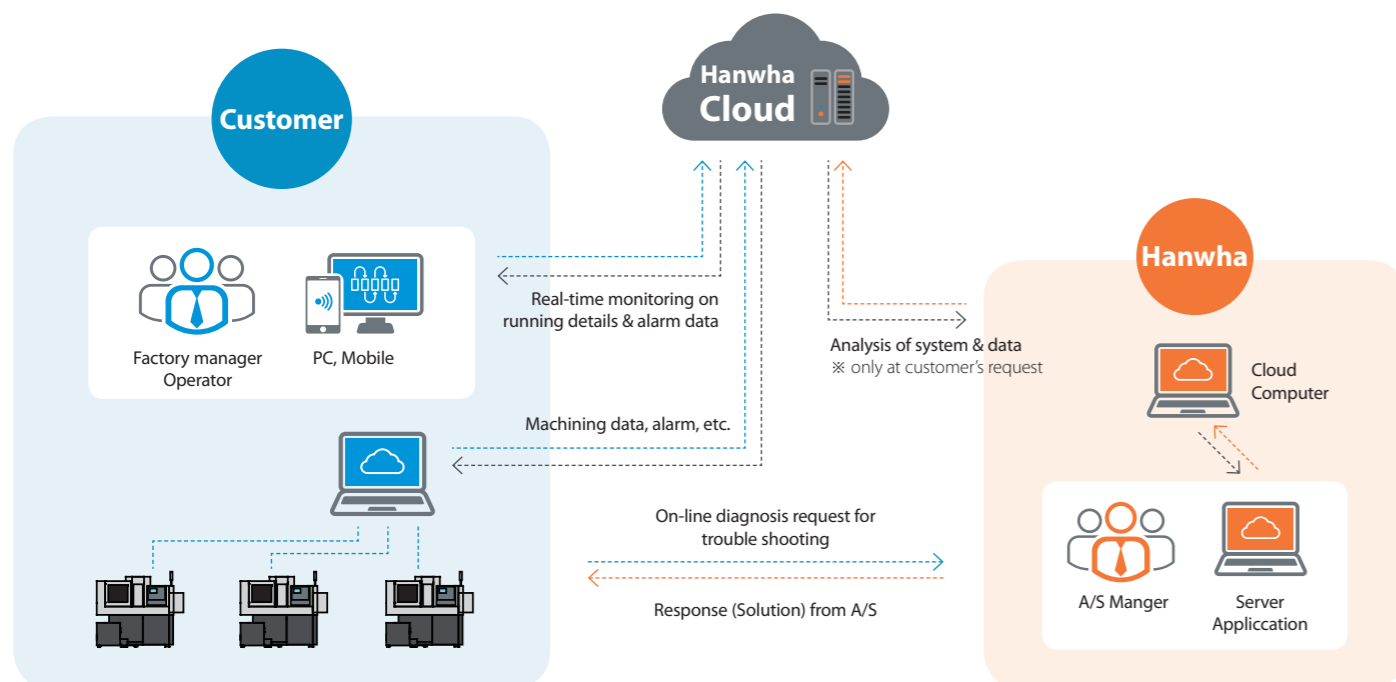

# PCR / PCRS & Oscillation

## Chip breaking solution



Hanwha provides chip cutting solution to break long and curled chips into small pieces through macro program.

### Advantage

- Better tool life
- Build-up edge free
- Chip trouble free
- Coolant usage saved



Model	PCR	PCRS	Oscillation
NC	FANUC 32i-B	SIEMENS 828D/840D	Fanuc 0i-TD / 0i-TF / 32i-B
Front turning	•	•	•
Back turning	•	•	•
Back drilling	Fixed drills	•	Fixed drills
Taper	•	•	45° angle
Circular interpolation	•	•	•
Synchronous control	•	•	x
Threading	•	•	x
Nose R compensation	x	•	x

# Customer & Performance Supporting Function

Hanwha offers various software for enhancing machining performance & supporting customer's convenience.

- Quick Measuring Setting time reduce system**  
 Supports tools setting with minimal control and none of screen change
- Collision Protection**  
 Easy setting of value to protect collision before occurring

- Tool Load Monitoring**  
 Alarms when abnormal load on tools are detected
- M7**  
 Single code to command cut-off of material

- 3D Chamfer Solution**  
 Uniform chamfer machining on cross hole with input of single code
- G301**  
 Single code to set the position of Z2-axis for cut-off of material

- Motion Optimization C/T reduce system**  
 Reduces cycle time by minimizing unnecessary motion (non processing time)
- Help function**  
 Provides description & graphic information about codes & alarms with

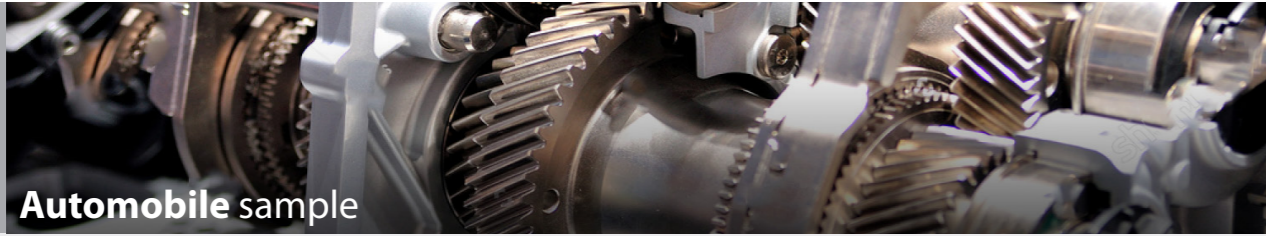

Automobile sample



































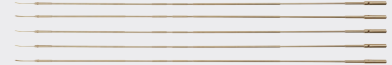













Electronic sample



Industrial sample



Medical sample

NO. Material	 <b>A001</b> SUM22	 <b>A002</b> SUS304	 <b>A003</b> SCM440H	NO. Material	 <b>E001</b> SUS316	 <b>I001</b> AL6062	 <b>M001</b> Titanium
NO. Material	 <b>A004</b> SUS304	 <b>A005</b> SUS304	 <b>A006</b> SUS304	NO. Material	 <b>E002</b> AL6061	 <b>I002</b> SUS316	 <b>M002</b> SUS316L
NO. Material	 <b>A007</b> SUM22	 <b>A008</b> SUS630	 <b>A009</b> SUM24	NO. Material	 <b>E003</b> AL6062	 <b>I003</b> AL2024	 <b>M003</b> Titanium
NO. Material	 <b>A010</b> AL6062-T8	 <b>A011</b> AL6062-T8	 <b>A012</b> AL6062-T9	NO. Material	 <b>E004</b> AL6061	 <b>I004</b> AL2024	 <b>M004</b> Titanium
NO. Material	 <b>A013</b> Brass	 <b>A014</b> AL-Die Casting	 <b>A015</b> SUM22	NO. Material	 <b>E005</b> Brass	 <b>I005</b> AL6062	 <b>M005</b> Titanium, Brass
NO. Material	 <b>A016</b> SUS316	 <b>A017</b> SUS304	 <b>A018</b> SUS303	NO. Material	 <b>E006</b> AL6061	 <b>I006</b> AL6062	 <b>M006</b> Titanium, Brass
NO. Material	 <b>A019</b> SCM315	 <b>A020</b> AL6062	 <b>A021</b> Brass	NO. Material	 <b>E007</b> Brass	 <b>I007</b> SUS316	 <b>M007</b> SUS316
NO. Material	 <b>A022</b> AL6061	 <b>A023</b> SUS304	 <b>A024</b> SUM202	NO. Material	 <b>E008</b> AL6062	 <b>I008</b> Brass	 <b>M008</b> Titanium